



MATRIX

# STRENGTH

2026 BROCHURE



# CONTENTS

## **4 BELIEVE IN BETTER**

*TOTAL SOLUTIONS PARTNER*

## **8 MATRIX STRENGTH OVERVIEW**

*STRENGTH THAT NEVER RESTS*

## **12 ULTRA SERIES**

*THE ULTIMATE STRENGTH  
TRAINING EXPERIENCE*

## **30 VERSA SERIES**

*THE POWER OF CHOICE IN  
STRENGTH TRAINING*

## **52 AURA SERIES**

*THE STANDARD IN PERFORMANCE  
AND DESIGN*

## **78 GO SERIES**

*DISCOVER THE STRENGTH OF SIMPLICITY*

## **90 MAGNUM SERIES**

*A LEGACY OF PERFORMANCE AND  
PROVEN DURABILITY*

## **144 XULT SERIES**

*DESIGNED FOR SUPERIOR VALUE  
AND TRAINING VARIETY*

## **160 ACCESSORIES**

*ACCESSORIES ELEVATE EXERCISE  
IN ALL THE RIGHT WAYS*

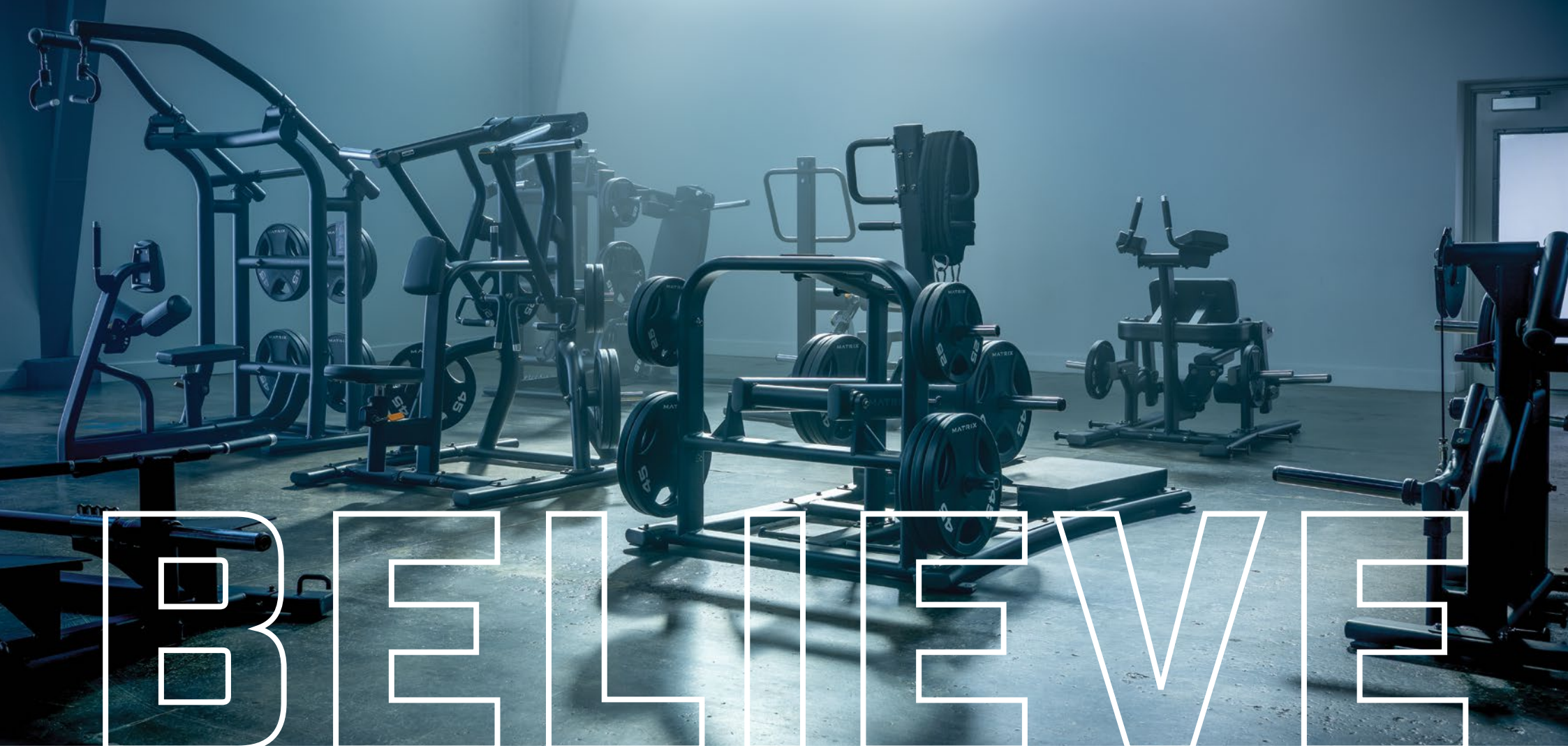

A man with a beard and short hair, wearing a red t-shirt, is shown from the chest up, working out on a Matrix gym machine. He is looking intently to the left. The machine is dark blue and has the word 'MATRIX' visible on its frame. The background is dark and out of focus.

# IN BETTER

At Matrix, it's our mission to make your fitness facility everything you ever dreamed it could be.

Count on us for meaningful innovations that make our equipment a joy to own, service and use. Expect a technology ecosystem that enhances the way you manage your facility, retain and engage members and promote your brand. And as always, trust us to put your brand and your business first, supporting you with facility planning, dedicated sales and support, unmatched customer service and extensive education and training.

**For all those who believe in better, there's Matrix.**



# BELIEVE

IN PARTNERSHIP THAT EMPOWERS

When you choose Matrix, you're getting more than the world's finest fitness equipment.  
You get a partner who will be there for your grand opening and every day after.



## DESIGNING YOUR SUCCESS

Building a fitness area is about creating a lasting asset for your facility. Our team works with you to select the perfect combination of equipment and technology that fits your unique requirements. With flexible financial options, we make it easy to turn your ideas into reality while staying within your budget.



## DELIVERING YOUR GOALS

We ensure a smooth start by handling setup and offering comprehensive guidance on maximizing the impact of your new fitness space. Your team will have all the knowledge they need to deliver an engaging experience from day one.



## SUPPORTING YOUR GROWTH

Count on Matrix for responsive service and swift issue resolution. Our commitment extends beyond installation, with readily available parts and marketing support kits designed to connect with your audience and spotlight your distinct fitness offering. Gain access to expert tools and resources that deliver valuable insights to your organization and help you make the most of your Matrix equipment and programming.

# STRENGTH OVERVIEW

Matrix doesn't just manufacture strength equipment — we craft training tools that evolve with your fitness facility and your lifters. We listen to owners, trainers and users to put real-world insights at the heart of our designs, captivating a new generation and delivering innovation that outperforms the ordinary in better, smarter ways. Best of all, we built on the decades of strength manufacturing experience through the acquisition of Magnum Fitness Systems, and continue to design and develop all of our durable training tools in the USA, the global epicenter of strength training.

**Choose Matrix, and discover strength that never rests.**



## ULTRA SERIES

### THE ULTIMATE EXPERIENCE

Powerful yet comfortable. Advanced functionality with intuitive operation. The industry's most durable components wrapped in breathtaking industrial design. The Ultra Series goes beyond your expectations of strength training equipment to earn and retain members like nothing else.



## VERSA SERIES

### THE POWER OF CHOICE

Bring your vision of fitness to life — our most versatile series gives you the options to build a strength training area that fits your space and the needs of your members in a beautifully precise way. The Versa Series incorporates advanced biomechanics for a natural, smooth, efficient workout experience.



## AURA SERIES

### PREMIUM PERFORMANCE & DESIGN

Superior styling made the Aura Series an instant classic. Signature features made it one of the most-imitated product lines in the industry. Choose the Aura Series, and you'll discover that beginners and fitness enthusiasts alike will be drawn to something that the competition can't imitate — an unmistakable aura of greatness.



## GO SERIES

### THE STRENGTH OF SIMPLICITY

Now you can engage users new to strength training and circuit programs with our easy-to-use, space-efficient Go Series. Minimal adjustments, low starting weights and smaller progressions create a welcoming experience where anyone can sit and go, while compact footprints, back-to-back designs and low stack heights fit your space and budget.



## MAGNUM SERIES

### PROVEN PERFORMANCE & DURABILITY

Born from a long tradition of premium performance, there's no better choice for professional athletes than the unrivaled performance and durability of the Magnum Series. Advanced options like Breaker Benches and MEGA Racks help athletes reach their potential, and the impeccable designs stand up to the most demanding environments.



## XULT SERIES

### PERFORMANCE, VALUE & VARIETY

For a blend of performance and value perfect for heavy-use facilities, look no further than the Xult Series. It offers the dynamic performance and superior ergonomics that the fitness world has come to expect from Matrix, plus the uncompromising durability you need to accommodate a steady stream of users.

# MORE THAN ONE WAY TO BUILD STRENGTH

We offer a complete collection of strength equipment to meet the needs of not just your people, but your space, too.

## **SINGLE-STATION**

Operation is intuitive, and our high-performance designs ensure that your members are getting the most out of every moment they spend pursuing their fitness goals.

ULTRA / VERSA / AURA / GO

## **PLATE-LOADED**

Thoughtful design and attention to detail make our stations easier to load, unload and access, so members can get the workout they need, where they need it, and keep going.

MAGNUM / XULT

## **MULTI-STATION**

Multi-station units make the most of your floor space and help members make the most of their workout time. Smart designs let users take on multiple exercises in a small space, with quick weight adjustments to maximize results.

VERSA / AURA / GO

## **RACKS, RIGS & PLATFORMS**

When serious strength training enthusiasts see our premium racks on your floor, they'll know they're in the right place and keep coming back for more.

MAGNUM / XULT

## **FREE WEIGHTS**

Choose from our unique series to find the combination of iron and ergonomics right for your facility, and count on exclusive features and industrial design to attract aspiring fitness enthusiasts and seasoned lifters alike.

MAGNUM / XULT / GO

# THE ULTIMATE STRENGTH TRAINING EXPERIENCE

## ULTRA SERIES

The powerful and comfortable Ultra Series gives you the most advanced functionality with an intuitive design that couldn't be easier to operate. Both durable and beautiful, the Ultra Series will exceed your expectations when it comes to earning and retaining members.

MATRIX



# ULTRA SERIES

## **ACTION SPECIFIC GRIPS™**

Ergonomically designed to reduce stress on contact points while enhancing feel, function and form.

## **LOW STACK HEIGHT**

A uniformly low stack height (135 cm / 53") improves the aesthetic and flow of your fitness center.

## **INDEPENDENT CONVERGING/DIVERGING MOTION**

Encourages a natural path of motion to enhance comfort.

## **INCREMENTAL WEIGHTS**

Easy to access and reference from the seated position.

## **USER AMENITIES**

All single-station units offer a convenient accessory pad, personal device holder and towel hook.

## **ELECTRONIC REP COUNTER**

Tracks reps, activity time and rest time for enhanced user data tracking and a streamlined workout experience.

## **EXERCISE PLACARDS**

Easy-to-read reference cards highlight targeted muscle groups and proper machine use.

## **ULTRA OPTIONS**

- Choose between Standard and Heavy Weight Stacks.
- Add Intelligent Training Console for a guided, fully connected strength training experience.

\*Ultra Base models exclude Action Specific Grips, electronic rep counters, aluminum tops, incremental weights and aluminum seat links.



# ULTRA INTELLIGENT TRAINING CONSOLE

When you choose Ultra Series with Intelligent Training Console, you'll get a digitally connected, guided experience. The intuitive touchscreen makes it easy for members of all levels to define physical transformation targets, identify their benchmark weight and receive step-by-step instructions. Then members can take on personalized progression programs that will help them reach their goals in smart new ways.

With convenience features like touch-free RFID login and stored seat settings, they'll be able to easily start a workout, transition between equipment and review previous workouts to chart their development—maximizing their time and results. Our WiFi-enabled console also works seamlessly with our digital portfolio of Connected Solutions, including Engage 360, Community 360 and Facility 360 Powered by Ecofit.



### A GUIDED TRAINING EXPERIENCE

Ideal for those new to strength training or experienced members who are struggling to progress. Intelligent Training Console features Endurance, Build and Strength programs to give members a guided training experience specific to their goals.

### ORIGINAL PROGRESSIONS

Original progression-based programming designed in collaboration with the National Strength and Conditioning Association (NSCA) helps members find a benchmark weight and provides 8–12 weeks of workouts to maximize results.

### EXPLOSIVE LIFTING

The explosive lifting program focuses on speed and power instead of just strength, helping members accelerate results while keeping the strength training experience fresh.

### WORKOUT HISTORY

Workout history snapshot lets members quickly review past sessions and track overall progress.

### DEMO VIDEOS

On-console demo videos provide guidance on maintaining proper form for each exercise.

### INTUITIVE NAVIGATION

Intuitive touchscreen console navigation makes it easy for members of any ability or experience level to get started.

### DUAL USER SIGN-IN

Dual user sign-in streamlines transitions between two alternating users and their specific strength training programs.

### RECORDED SETTINGS

Stored seat settings make it easy for users to find the same ergonomically sound fit every time they work out.

### TOUCH-FREE LOGIN

Included RFID capability gives users a quick, touch-free way to login, load their personal preferences and start their workout.

### FULLY CONNECTED TECHNOLOGY

Internet connectivity via WiFi or ethernet provides access to included Facility 360 Powered by Ecofit and optional add-ons, such as Community 360 and Engage 360.

### BRAND-BUILDING CUSTOMIZATION

Customizable interface strongly represents your brand to provide a unified look and feel throughout your entire facility.

### INTELLIGENT TRAINING CONSOLE SPECIFICATIONS

#### CONSOLE

Display Type	40.6 cm / 16" capacitive touchscreen LCD
Display Feedback	Reps, sets, rest time, heart rate, total weight, lift time
Workouts	Manual, endurance, build, custom, strength, explosive lifts
User-defined Multi-language Display	English, German, French, Italian, Spanish, Dutch, Portuguese, Chinese, Japanese, Korean, Swedish, Finnish, Russian, Arabic, Turkish, Polish, Welsh, Basque, Vietnamese, Somali, Danish, Malay, Catalan, Thai, Greek
Lift to Start	Yes
Ethernet	Yes
WiFi	Yes
Bluetooth	Heart rate only
USB Port	Software updates only
RFID Wireless Login	Yes
Dual User Sign-in	Yes
CSAFE Ready	No
Community 360 Compatible	Yes
Facility Communication Portal / Calendar	No
Engage 360 Compatible	Yes
EGYM Compatible	Yes
Facility 360 Compatible	Included
Stored User Settings	Yes- Seat settings and Bluetooth HR
Strength Series Compatibility	Ultra Series June 2022 or newer

#### TECH SPECS

Power Requirements	100-240V / 50-60Hz AC
Assembled Dimensions	147.3 cm / 58" (As assembled on the Ultra weight stack)
Shipping Dimensions	51 x 42 x 25 cm / 20.1" x 16.5" x 9.8"
Shipping Weight	9.4 kg / 21 lbs.



### CONVERGING CHEST PRESS

Independent converging movement provides a natural path of motion • Adjustable back pad with gas assist facilitates easy range of motion changes • Integrated foot platform provides additional user stability and comfort during use • Designed for easy entry and exit • Ultra Base G7-S13B and Ultra Base Heavy Stack G7-S13BH

	PRODUCT DIMENSIONS (L X W X H)						PRODUCT WEIGHT		WEIGHT STACK	
	CM			INCHES			KG	LBS	KG	LBS
<b>G7-S13</b>	168.5	141	135	66.3	55.4	53	343.9	758.5	108	240



### LATERAL RAISE

Oversized arm pads enhance comfort and accommodate a variety of users • Rotating handles provide natural motion • Available as Ultra Base G7-S21B and Ultra Base Heavy Stack G7-S21BH

	PRODUCT DIMENSIONS (L X W X H)						PRODUCT WEIGHT		WEIGHT STACK	
	CM			INCHES			KG	LBS	KG	LBS
<b>G7-S21</b>	105.5	150	135	41.5	59	53	276.8	610.5	90	200



### PEC FLY / REAR DELT

Rotating grips provide comfort and smooth movement during use • Angled back pad and delt grips enhance user comfort and improve biomechanics • Oversized handles reduce the need to adjust the seat position between rear deltoid and fly exercises • Heavy weight stack accommodates advanced users • Available as Ultra Base G7-S22B and Ultra Base Heavy Stack G7-S22BH

	PRODUCT DIMENSIONS (L X W X H)						PRODUCT WEIGHT		WEIGHT STACK	
	CM		INCHES				KG	LBS	KG	LBS
	<b>G7-S22</b>	143.5	193.5	197	56.4	76.1	77.6	322.2	710.5	135



### CONVERGING SHOULDER PRESS

Independent converging movement provides a natural path of motion • Dual-position hand grips allow for greater training variety • Counterbalanced pressing arms provide reduced starting resistance • Reclining seat position allows for better posture and back support • Available as Ultra Base G7-S23B and Ultra Base Heavy Stack G7-S23BH

	PRODUCT DIMENSIONS (L X W X H)						PRODUCT WEIGHT		WEIGHT STACK	
	CM		INCHES				KG	LBS	KG	LBS
	<b>G7-S23</b>	168	146.5	174	66.1	57.6	68.4	275.5	607.5	90



### DIVERGING LAT PULLDOWN

Independent diverging movement provides a natural path of motion • Angled seat encourages proper user position • High pads and seat easily adjust to provide stability, comfort and improved ergonomics • Available as Ultra Base G7-S33B and Ultra Base Heavy Stack G7-S33BH

	PRODUCT DIMENSIONS (L X W X H)						PRODUCT WEIGHT		WEIGHT STACK	
	CM			INCHES			KG	LBS	KG	LBS
<b>G7-S33</b>	152	161	195	59.6	63.1	76.7	380	838	108	240



### DIVERGING SEATED ROW

Independent diverging movement provides a natural path of motion • Dual-position foot placement provide greater user comfort • Adjustable chest pad with gas shock accommodates a variety of users • Available as Ultra Base G7-S34B and Ultra Base Heavy Stack G7-S34BH

	PRODUCT DIMENSIONS (L X W X H)						PRODUCT WEIGHT		WEIGHT STACK	
	CM			INCHES			KG	LBS	KG	LBS
<b>G7-S34</b>	158	138.5	140.5	62.2	54.5	55.3	344	758.5	108	240



### INDEPENDENT BICEPS CURL

Unique pivoting elbow pads and rotating handles improve function, comfort and feel during use • Designed for easy entry and exit without chest compression from traditional machines • Elbow pad wear covers improve upholstery performance in high contact areas • Available as Ultra Base G7-S40B and Ultra Base Heavy Stack G7-S40BH

	PRODUCT DIMENSIONS (L X W X H)						PRODUCT WEIGHT		WEIGHT STACK	
	CM		INCHES				KG	LBS	KG	LBS
<b>G7-S40</b>	135	168	135	53	66.2	53	263.6	581.5	90	200



### DEPENDENT ARM CURL

Rotating Action Specific Grips™ provide greater comfort and minimal point pressure • Arm pad is angled for stability and limits unwanted shoulder movement during exercise • Elbow pad wear cover improves upholstery performance and durability in high contact areas • Color-coded pivot indicates correct elbow placement for optimal feel and performance • Available as Ultra Base G7-S41B and Ultra Base Heavy Stack G7-S41BH

	PRODUCT DIMENSIONS (L X W X H)						PRODUCT WEIGHT		WEIGHT STACK	
	CM		INCHES				KG	LBS	KG	LBS
<b>G7-S41</b>	149	106.5	135	59	42	53	225.7	498	90	200



### TRICEPS PRESS

Oversized rotating handles adapt to a wide variety of users and provide exercise variation • Angled back pad reduces stress, improves stabilization and enhances comfort • Available as Ultra Base G7-S42B and Ultra Base Heavy Stack G7-S42BH

	PRODUCT DIMENSIONS (L X W X H)					PRODUCT WEIGHT		WEIGHT STACK		
	CM		INCHES			KG	LBS	KG	LBS	
<b>G7-S42</b>	124	121	135	48.8	47.7	53	298.5	658	120	265



### TRICEPS EXTENSION

Handles pivot to automatically adjust for varying forearm lengths • Padded hand rests provide a comfortable and stable pressing surface while reducing point pressure on the hands • Action Specific Grips™ provide greater comfort and tailored hand position for the movement • Color-coded pivot indicates correct elbow placement for optimal feel and performance • Foot pegs provide additional stability and support during heavy lifts • Available as Ultra Base G7-S45B and Ultra Base Heavy Stack G7-S45BH

	PRODUCT DIMENSIONS (L X W X H)					PRODUCT WEIGHT		WEIGHT STACK		
	CM		INCHES			KG	LBS	KG	LBS	
<b>G7-S45</b>	144.5	106.5	135	57	42	53	239.2	527.5	81	180



### ABDOMINAL CRUNCH

Sculpted back pads allow for full muscular contraction • Dual-supported pivoting design fosters a natural abdominal crunch motion • Self-aligning handles adjust to accommodate a variety of users, and elbow pad covers protect the upholstery at touchpoints • Available as Ultra Base G7-S51B and Ultra Base Heavy Stack G7-S51BH

	PRODUCT DIMENSIONS (L X W X H)						PRODUCT WEIGHT		WEIGHT STACK	
	CM		INCHES				KG	LBS	KG	LBS
<b>G7-S51</b>	139	121	147	54.6	47.5	57.9	290	639.5	108	240



### BACK EXTENSION

Multi-position foot placement accommodates a variety of users • Thumb-switch controls allow easy adjustments • Contoured back pad enhances user comfort and provides additional support • Available as Ultra Base G7-S52B and Ultra Base Heavy Stack G7-S52BH

	PRODUCT DIMENSIONS (L X W X H)						PRODUCT WEIGHT		WEIGHT STACK	
	CM		INCHES				KG	LBS	KG	LBS
<b>G7-S52</b>	145	120	135	57.2	47.3	53	316.1	697	108	240



### ROTARY TORSO

Kneeling position minimizes low-back stress while stretching hip flexors • Contoured kneed pads enhance comfort, stability and durability • Wear covers in high contact areas improve upholstery performance • 8 different start positions add greater versatility and range of motion • Available as Ultra Base G7-S55B and Ultra Base Heavy Stack G7-S55BH

	PRODUCT DIMENSIONS (L X W X H)						PRODUCT WEIGHT		WEIGHT STACK	
	CM		INCHES				KG	LBS	KG	LBS
<b>G7-S55</b>	117	123	141	45.8	48.2	55.2	229	505	90	200



## LEG PRESS

Angled and adjustable seat carriage enhances comfort • Ergonomic adjustment handle and gas shock enable simple changes in start position • Oversized foot platform increases movement variety including calf exercises • Integrated assistance handle enables easy exit and entry • Guide rod and bearing-designed carriage improves long-term durability and smooth performance • Available as Ultra Base G7-S70B and Ultra Base Heavy Stack G7-S70BH

	PRODUCT DIMENSIONS (L X W X H)						PRODUCT WEIGHT		WEIGHT STACK	
	CM			INCHES			KG	LBS	KG	LBS
<b>G7-S70</b>	206	113	152	80.9	44.3	59.9	440	970	180	400



## LEG EXTENSION

Self-adjusting tibia pad for greater ease of use • Soft contoured knee pad provides optimal comfort behind user's knee during use • Thumb-switch controls and ergonomic adjustment handle allow easy user setup • Angled seat and back pads encourage full quadriceps contraction • Pivot location clearly marked to encourage correct knee alignment • Available as Ultra Base G7-S71B and Ultra Base Heavy Stack G7-S71BH

	PRODUCT DIMENSIONS (L X W X H)						PRODUCT WEIGHT		WEIGHT STACK	
	CM			INCHES			KG	LBS	KG	LBS
<b>G7-S71</b>	152.4	125.9	135	60	49.6	53	299.7	661	108	240



### SEATED LEG CURL

Back pad, tibia pad and range-of-motion adjustments are easily accessible from a seated position • Angled seat and unique pivot location encourage full hamstring contraction • Adjustable thigh pad with thumb switch control allow easy user setup • Soft contoured thigh pad provides optimal comfort during use • Available as Ultra Base G7-S72B and Ultra Base Heavy Stack G7-S72BH

	PRODUCT DIMENSIONS (L X W X H)						PRODUCT WEIGHT		WEIGHT STACK	
	CM		INCHES				KG	LBS	KG	LBS
<b>G7-S72</b>	148.5	117	135	58.4	46	53	314.7	694	90	200



### PRONE LEG CURL

Contoured elbow pads enhance stabilization and comfort • Divergent pad angle eliminates lower-back stress • Integrated sweat guard protects frame from damage • Thumb-switch controls allow easy adjustments • Available as Ultra Base G7-S73B and Ultra Base Heavy Stack G7-S73BH

	PRODUCT DIMENSIONS (L X W X H)						PRODUCT WEIGHT		WEIGHT STACK	
	CM		INCHES				KG	LBS	KG	LBS
<b>G7-S73</b>	173	112	135	68	44	53	271.5	598.5	90	200



### HIP ADDUCTOR

Ergonomic adjustment handle enables simple changes in start position • Foot pegs and contoured knee pads provide user stabilization and support • Adjustable reclining position offers customized lumbar comfort • Integrated foot platform allows easy exit and entry • Available as Ultra Base G7-S74B and Ultra Base Heavy Stack G7-S74BH

	PRODUCT DIMENSIONS (L X W X H)			PRODUCT WEIGHT		WEIGHT STACK	
	CM	INCHES		KG	LBS	KG	LBS
<b>G7-S74</b>	182	173	135	71.6	67.8	53	270.2 596 90 200



### HIP ABDUCTOR

Ergonomic adjustment handle enables simple changes in start position • Foot pegs and contoured knee pads provide user stabilization and support • Adjustable reclining position offers customized lumbar comfort • Integrated foot platform allows easy exit and entry • Available as Ultra Base G7-S75B and Ultra Base Heavy Stack G7-S75BH

	PRODUCT DIMENSIONS (L X W X H)			PRODUCT WEIGHT		WEIGHT STACK	
	CM	INCHES		KG	LBS	KG	LBS
<b>G7-S75</b>	182	173	135	71.6	68	53	272.2 600 90 200



### CALF EXTENSION

Angled seat position provides greater lumbar support • Ergonomic adjustment handle enables simple changes in start position • Range-of-motion adjustment accommodates a variety of users and start positions • Guide rod and bearing-designed carriage improves long-term durability and smooth performance • Available as Ultra Base G7-S77B and Ultra Base Heavy Stack G7-S77BH

	PRODUCT DIMENSIONS (L X W X H)					PRODUCT WEIGHT		WEIGHT STACK		
	CM	CM	CM	INCHES	INCHES	KG	LBS	KG	LBS	
<b>G7-S77</b>	169	120	150	66.5	47.2	59	291	642	180	400



### GLUTE

Upright user position increases comfort and machine approachability • Rotating foot pad provides stable and smooth contact throughout the full range of motion • Oversized foot platform bolsters stability • Adjustable chest pad accommodates a variety of users • Available as Ultra Base G7-S78B and Ultra Base Heavy Stack G7-S78BH

	PRODUCT DIMENSIONS (L X W X H)					PRODUCT WEIGHT		WEIGHT STACK		
	CM	CM	CM	INCHES	INCHES	KG	LBS	KG	LBS	
<b>G7-S78</b>	200.5	90	156	79	35.3	61.5	232	511	63	140



### HIP THRUST

Closely mimics bar hip thrusting while removing the difficulty, danger and discomfort of a standard Olympic bar exercise • Floating hip pad maintains correct position during exercise • Oversized foot platform bolsters stability and provides consistent positioning • Available as Ultra Base G7-S79B and Ultra Base Heavy Stack G7-S79BH

	PRODUCT DIMENSIONS (L X W X H)					PRODUCT WEIGHT		WEIGHT STACK		
	CM	CM	CM	INCHES	INCHES	KG	LBS	KG	LBS	
<b>G7-S79</b>	175	149.5	135	69	59	53	384	847	189	420

**ULTRA STANDARD FRAME COLORS**



Iced Silver†



Black Glossy



Matte Black†

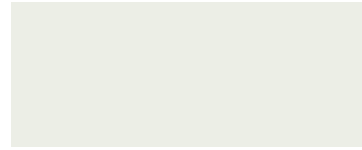

Lace White



Polarized Titanium

**ULTRA UPHOLSTERY COLOR OPTIONS**



Black



Slate Blue



Clay Red



Graphite



Alloy

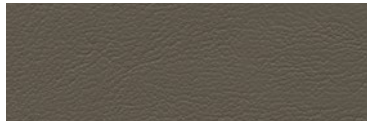

Hazelnut

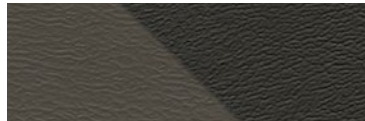

Alloy / Graphite

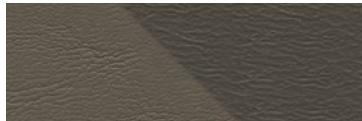

Hazelnut / Alloy



American Beauty



Candy Apple



New Burgundy



Paprika



Nasturtium



Mandarin Orange



Sun Yellow



Marigold



Emerald



Hunter Green



Royal Blue



Bluejay



Deep Violet



Navy



Bucksuede



Allspice



Cadet

Frame and upholstery colors applicable to the USA. Product pricing is reflective of **standard** upholstery only. Other color options available at an additional charge. NOTE: Actual product colors may vary from what is shown here. † Stocked frame color. Additional lead times may apply for other frame colors



# THE POWER OF CHOICE IN STRENGTH TRAINING

## **VERSA** SERIES

The Versa Series offers a wide range of options — like standard or heavy weight stacks and optional foot support kits — so you can assemble a collection just right for your space, members and budget. Count on the Versa Series for a mix of advanced biomechanics and smart options that will bring your vision of fitness to life.



# VERSA SERIES

## **ACTION SPECIFIC GRIPS™**

Ergonomically designed to reduce stress on contact points while enhancing feel and form. (Versa+ package)

## **CONVERGING/DIVERGING MOTION**

Encourages a natural path of motion to enhance comfort.

## **INCREMENTAL WEIGHTS**

Easy to access and reference from the seated position (Versa+ package only).

## **GAS-ASSISTED SEAT ADJUSTMENT**

Offers smooth, instant adjustment, with a 4-bar linkage for increased stability. (Versa+ package)

## **ELECTRONIC REP COUNTER**

Tracks reps, activity time and rest time for a streamlined workout experience. (Versa+ package)

## **EXERCISE PLACARDS**

Easy-to-read reference cards highlight targeted muscle groups and proper machine use.



## VERSA OPTIONS

### VERSA+

(shown throughout brochure)

Comes with:

- Action Specific Grips
- Gas-assisted Seat Adjustment
- Electronic Rep Counter/Timer
- Decorative Top Wing
- Ergonomic Adjustment Handles
- Heavy Weight Stack
- Incremental Weight

### WEIGHT STACK

- Choose between Standard and Heavy Weight Stack

### OPTIONAL FOOT SUPPORT KIT

Available on:

- Converging Chest Press
- Converging Shoulder Press
- Biceps Curl
- Back Extension





## CONVERGING CHEST PRESS

Independent converging movement provides a natural path of motion • Designed for easy entry and exit • Adjustable start position facilitates increased range of motion

	PRODUCT DIMENSIONS (L X W X H)						PRODUCT WEIGHT		WEIGHT STACK	
	CM		INCHES				KG	LBS	KG	LBS
<b>VS-S13</b>	139.3	134.7	162.5	54.9	53	64	262	578	72	160
<b>VS-S13P</b>	139.3	134.7	167.1	54.9	53	65.8	297	654	104	230
<b>VS-S13H</b>	139.3	134.7	162.5	54.9	53	64	294	648	104	230



## CONVERGING SHOULDER PRESS

Independent converging movement provides a natural path of motion • Dual-position hand grips allow for greater training variety • Counterbalanced pressing arms provide reduced starting resistance

	PRODUCT DIMENSIONS (L X W X H)						PRODUCT WEIGHT		WEIGHT STACK	
	CM		INCHES				KG	LBS	KG	LBS
<b>VS-S23</b>	171	143.7	203.6	67.3	56.6	80.1	266	585	72	160
<b>VS-S23P</b>	171	143.7	203.6	67.3	56.6	80.1	300	661	104	230
<b>VS-S23H</b>	171	143.7	203.6	67.3	56.6	80.1	297	655	104	230



### DIVERGING LAT PULLDOWN

Independent diverging movement provides a natural path of motion • Angled seat encourages proper user position • Thigh pad easily adjusts for stability and comfort

	PRODUCT DIMENSIONS (L X W X H)						PRODUCT WEIGHT		WEIGHT STACK	
	CM		INCHES				KG	LBS	KG	LBS
<b>VS-S33</b>	155.4	150.1	187.9	61.2	59.1	74	262	578	72	160
<b>VS-S33P</b>	155.4	150.1	187.9	61.2	59.1	74	297	654	104	230
<b>VS-S33H</b>	155.4	150.1	187.9	61.2	59.1	74	294	648	104	230



### DIVERGING SEATED ROW

Independent cable movement provides a user-defined path of motion and exercise variety • Adjustable chest pad accommodates users of all sizes • Rotating grips provide maximum comfort and ergonomic hand positioning throughout the range of motion • Integrated foot pegs provide added support during heavy lifts

	PRODUCT DIMENSIONS (L X W X H)						PRODUCT WEIGHT		WEIGHT STACK	
	CM		INCHES				KG	LBS	KG	LBS
<b>VS-S34</b>	137.8	99.4	162.5	54.2	39.1	64	228	503	72	160
<b>VS-S34P</b>	137.8	99.4	167.1	54.2	39.1	65.8	263	579	104	230
<b>VS-S34H</b>	137.8	99.4	162.5	54.2	39.1	64	260	573	104	230

\*Products shown as Versa+



## BICEP CURL

Arm pad is angled for stability and limits unwanted shoulder movement during exercise • Optimized pivot location creates biomechanically correct range of motion

	PRODUCT DIMENSIONS (L X W X H)						PRODUCT WEIGHT		WEIGHT STACK	
	CM		INCHES				KG	LBS	KG	LBS
<b>VS-S40</b>	121.8	127	162.5	48	50	64	253	558	68	150
<b>VS-S40P</b>	121.8	127	167.1	48	50	65.8	279	614	90	200
<b>VS-S40H</b>	121.8	127	162.5	48	50	64	276	608	90	200



## TRICEPS PRESS

Rotating handles adapt to users of all sizes • Angled back pad reduces stress, improves stabilization and enhances comfort

	PRODUCT DIMENSIONS (L X W X H)						PRODUCT WEIGHT		WEIGHT STACK	
	CM		INCHES				KG	LBS	KG	LBS
<b>VS-S42</b>	157.7	107.5	162.5	62.1	42.3	64	259	571	72	160
<b>VS-S42P</b>	157.7	107.5	167.1	62.1	42.3	65.8	294	647	104	230
<b>VS-S42H</b>	157.7	107.5	162.5	62.1	42.3	64	291	641	104	230



### BACK EXTENSION

Multi-position foot placement accommodates a variety of users • Contoured back pad enhances comfort

	PRODUCT DIMENSIONS (L X W X H)					PRODUCT WEIGHT		WEIGHT STACK		
	CM	INCHES				KG	LBS	KG	LBS	
<b>VS-S52</b>	133.5	126.4	162.5	52.6	49.8	64	227	500	72	160
<b>VS-S52P</b>	133.5	126.4	167.1	52.6	49.8	65.8	262	576	104	230
<b>VS-S52H</b>	133.5	126.4	162.5	52.6	49.8	64	259	570	104	230



### ABDOMINAL

3-position design trains abdominals and obliques for added exercise variety and core rotation • Ergonomic back pad improves range of motion and enhances comfort

	PRODUCT DIMENSIONS (L X W X H)					PRODUCT WEIGHT		WEIGHT STACK		
	CM	INCHES				KG	LBS	KG	LBS	
<b>VS-S53</b>	136.6	141.4	162.5	53.8	55.7	64	213	470	72	160
<b>VS-S53P</b>	136.6	141.4	167.1	53.8	55.7	65.8	248	546	104	230
<b>VS-S53H</b>	136.6	141.4	162.5	53.8	55.7	64	245	540	104	230

\*Products shown as Versa+



## LEG PRESS/CALF PRESS

One-handed start adjustment for ease of use • Gas-assisted foot platform provides smoother adjustments • Assistance handle and low step-over height offer easy access • Foot plate identifies user foot position with unique visual indicators

	PRODUCT DIMENSIONS (L X W X H)						PRODUCT WEIGHT		WEIGHT STACK	
	CM	INCHES					KG	LBS	KG	LBS
<b>VS-S70</b>	232.4	102.4	162.5	91.5	40.3	64	361	795	188	415
<b>VS-S70P</b>	232.4	102.4	167.1	91.5	40.3	65.8	364	801	188	415
<b>VS-S70H</b>	232.4	102.4	162.5	91.5	40.3	64	361	795	188**	415**



## LEG EXTENSION

Angled seat and back pads encourage full quadriceps contraction • Self-adjusting tibia pad enhances comfort • Pivot location is clearly marked to encourage correct alignment • Back pad ratchets forward for easy adjustment from seated position

	PRODUCT DIMENSIONS (L X W X H)						PRODUCT WEIGHT		WEIGHT STACK	
	CM	INCHES					KG	LBS	KG	LBS
<b>VS-S71</b>	183.5	128.9	162.5	72.3	50.7	64	233	514	72	160
<b>VS-S71P</b>	183.5	128.9	167.1	72.3	50.7	65.8	268	590	104	230
<b>VS-S71H</b>	183.5	128.9	162.5	72.3	50.7	64	265	584	104	230



### SEATED LEG CURL

Angled seat and unique pivot location encourage full hamstring contraction • Tibia pad and range-of-motion adjustments are easily accessible from seated position • Back pad ratchets forward for easy adjustment from seated position • Adjustable thigh pad provides stabilization during exercise

	PRODUCT DIMENSIONS (L X W X H)				PRODUCT WEIGHT		WEIGHT STACK			
	CM	INCHES			KG	LBS	KG	LBS		
<b>VS-S72</b>	176.9	113.3	162.5	69.7	44.6	64	261	575	68	150
<b>VS-S72P</b>	176.9	113.3	167.1	69.7	44.6	65.8	287	631	90	200
<b>VS-S72H</b>	176.9	113.3	162.5	69.7	44.6	64	284	625	90	200



### GLUTE

Adjustable chest pad accommodates users of all sizes • Low step-height stabilization platform allows for ease of use • Upright user position, contoured elbow pads and large foot pad enhance comfort

	PRODUCT DIMENSIONS (L X W X H)				PRODUCT WEIGHT		WEIGHT STACK			
	CM	INCHES			KG	LBS	KG	LBS		
<b>VS-S78</b>	177.8	99.9	162.5	70	39.3	64	185	409	68	150
<b>VS-S78P</b>	177.8	99.9	167.1	70	39.3	65.8	188	415	68	150
<b>VS-S78H</b>	177.8	99.9	162.5	70	39.3	64	185	409	68**	150**

\*Products shown as Versa+ \*\*VS-S70 and VS-S78 come standard with heavy weight stack

# MORE FUNCTION, LESS SPACE

## VERSA DUALS

The expanded versatility of our dual stations makes it easy to create a weight-training collection just right for your space, your budget and the people you serve. By mixing and matching a range of our two-in-one stations, you can make the most of your floor space while providing a complete strength training experience. Intuitive adjustment, incremental weight control and clearly illustrated placards make it easy for users of all ability levels to smoothly transition from one exercise to the next, while ergonomic design adds comfort to every workout. Choose from eight dual-station units, customize with weight stack options or our premium Versa+ package, and complete your offering with more Versa single-station units.





### MULTI-PRESS

Designed for easy entry and exit • Smoothly transition between exercises with one simple adjustment • Dual-position hand grips allow for greater training variety • Elevated foot rests provide stability and comfort during heavy lifts • Reclined position offers greater lumbar support • Clearly indicated adjustments for ease of use

	PRODUCT DIMENSIONS (L X W X H)						PRODUCT WEIGHT		WEIGHT STACK	
	CM		INCHES				KG	LBS	KG	LBS
<b>VS-S131</b>	154.3	157.2	199.9	60.7	61.9	78.7	236	520	72	160
<b>VS-S131P</b>	154.3	157.2	199.9	60.7	61.9	78.7	271	596	104	230
<b>VS-S131H</b>	154.3	157.2	199.9	60.7	61.9	78.7	268	590	104	230



### PEC FLY / REAR DELT

Comfortable, oversized grips accommodate users of all sizes • Always forward-facing user position enhances comfort and ease of use • Wide motion for improved biomechanics and dual function

	PRODUCT DIMENSIONS (L X W X H)						PRODUCT WEIGHT		WEIGHT STACK	
	CM		INCHES				KG	LBS	KG	LBS
<b>VS-S22</b>	150.5	169	162.5	59.2	66.5	64	224	492	68	150
<b>VS-S22P</b>	150.5	169	167.1	59.2	66.5	65.8	259	548	90	200
<b>VS-S22H</b>	150.5	169	162.5	59.2	66.5	64	256	542	90	200



### LAT PULLDOWN / SEATED ROW

Thigh pad easily adjusts to provide stability and comfort • Elevated foot-rests provide stability and comfort during heavy lifts • Stainless-steel cable guides provide added protection for lasting durability • Clearly indicated adjustments for ease of use

	PRODUCT DIMENSIONS (L X W X H)				PRODUCT WEIGHT		WEIGHT STACK			
	CM	INCHES	KG	LBS	KG	LBS	KG	LBS		
<b>VS-S331</b>	180.5	158	227	71.1	62.2	89.1	246	543	72	160
<b>VS-S331P</b>	180.5	158	227	71.1	62.2	89.1	281	619	104	230
<b>VS-S331H</b>	180.5	158	227	71.1	62.2	89.1	278	613	104	230

### BICEP / TRICEP

Compact design minimizes floor space • Stainless-steel cable guides provide added protection for lasting durability • Large foot platform provides stability

	PRODUCT DIMENSIONS (L X W X H)				PRODUCT WEIGHT		WEIGHT STACK			
	CM	INCHES	KG	LBS	KG	LBS	KG	LBS		
<b>VS-S401</b>	166.6	115.2	226.2	65.6	45.3	89.1	214	472	68	150
<b>VS-S401P</b>	166.6	115.2	226.2	65.6	45.3	89.1	240	528	90	200
<b>VS-S401H</b>	166.6	115.2	226.2	65.6	45.3	89.1	237	522	90	200

\*Products shown as Versa+



### AB / LOW BACK

Angled seat and lumbar pad enhance user comfort • Multi-position foot placement accommodates a variety of users • Low handle positions offer easy entry and exit and provide stability • Clearly indicated adjustments for ease of use

	PRODUCT DIMENSIONS (L X W X H)						PRODUCT WEIGHT		WEIGHT STACK	
	CM	INCHES					KG	LBS	KG	LBS
<b>VS-S531</b>	132.2	131.5	162.5	52.1	51.8	64	231	509	72	160
<b>VS-S531P</b>	132.2	131.5	167.1	52.1	51.8	65.8	266	585	104	230
<b>VS-S531H</b>	132.2	131.5	162.5	52.1	51.8	64	263	579	104	230



### CHIN / DIP ASSIST

Multi-position pull-up handles for greater exercise variety • Ideally angled dip grips encourage proper wrist placement and muscle variation • Gas-assisted knee platform folds up for unassisted bodyweight exercises and training variety • Large, textured foot platforms provide easy entry and exit • Knee platform features a protective top pad for added training security • Integrated hard stop prevents knee pad disengagement • Clearly indicated adjustments for ease of use

	PRODUCT DIMENSIONS (L X W X H)						PRODUCT WEIGHT		WEIGHT STACK	
	CM	INCHES					KG	LBS	KG	LBS
<b>VS-S601</b>	142.8	152.8	219.7	56.2	60.2	86.5	307	676	68**	150**
<b>VS-S601P</b>	142.8	152.8	219.7	56.2	60.2	86.5	310	682	68**	150**
<b>VS-S601H</b>	142.8	152.8	219.7	56.2	60.2	86.5	307	676	68**	150**



### LEG EXTENSION / LEG CURL

Angled pads and ideal pivot location promote full muscle contraction and alignment for both exercises • Dual-action CAM enables a smooth transition between exercises and prevents cable slack • Adjustments are easily performed in the seated position • Back pad ratchets forward for easy adjustment from the seated position • Clearly indicated adjustments for ease of use

	PRODUCT DIMENSIONS (L X W X H)					PRODUCT WEIGHT		WEIGHT STACK		
	CM	INCHES				KG	LBS	KG	LBS	
<b>VS-S711</b>	177.6	118.3	162.5	69.9	46.6	64	251	554	72	160
<b>VS-S711P</b>	177.6	118.3	167.1	69.9	46.6	65.8	286	630	104	230
<b>VS-S711H</b>	177.6	118.3	162.5	69.9	46.6	64	283	624	104	230



### HIP ADDUCTOR / ABDUCTOR

Dual-function machine saves space and increases functionality • Reclined position provides greater comfort • Clearly indicated adjustments allow for ease of use

	PRODUCT DIMENSIONS (L X W X H)					PRODUCT WEIGHT		WEIGHT STACK		
	CM	INCHES				KG	LBS	KG	LBS	
<b>VS-S74</b>	169.6	159.1	162.5	66.8	62.6	64	235	516	72	160
<b>VS-S74P</b>	169.6	159.1	167.1	66.8	62.6	65.8	269	592	104	230
<b>VS-S74H</b>	169.6	159.1	162.5	66.8	62.6	64	266	586	104	230

\*Products shown as Versa+ \*\*VS-601 comes standard with heavy weight stack

## MD LEG PRESS

Ideal for creating a wide range of progression programs, including isometric, loaded isometric, isotonic, plyometric, elastic and combined (elastic and weight stack) exercises • Low starting weight offers gradual progression • Adjustable shoulder pads, seat back and gas-assisted foot platform provide flexible progressions and comfortable use for clients of all sizes • Stack disconnect allows free movement of the carriage without additional resistance, ideal for deconditioned and injured clients • Band hooks make it easy to add external resistance bands for elastic and plyometric training • Carriage lockout and range-of-motion limiter restrict carriage movement for isometric contractions while protecting clients from overextending

Also available: optional incremental weights, step stool, force plate holder and MD-S70-AP accessory package



WEDGE BLOCK / HEEL CUP / ACCESSORY CRADLE / STOOL



	PRODUCT DIMENSIONS (L X W X H)						PRODUCT WEIGHT		WEIGHT STACK	
	CM	CM	CM	CM	INCHES	INCHES	KG	LBS	KG	LBS
<b>MD-S70</b>	263.7	121.9	188.3	103.8	48	74.2	372	820	136	300



### MD LEG EXTENSION / CURL

Ideal for creating a wide range of progression programs including exercises that build strength in the hamstrings and quads • Unique seat pivot allows proper joint alignment creating optimal biomechanics in both directions • Gas-assisted adjustments combined with a rotating thigh pad for open exit and entry provide an exceptional user experience • The range-of-motion limiter and 12 starting positions allow complete control over stroke length and isometric contractions • Low starting weight of 4.5 kg / 10 lbs. for the leg extension and 3.4 kg / 7.5 lbs. for the leg curl • Also available: optional incremental weights and step stool

	PRODUCT DIMENSIONS (L X W X H)						PRODUCT WEIGHT		WEIGHT STACK	
	CM		INCHES				KG	LBS	KG	LBS
<b>MD-S711</b>	217	125.4	162.5	85.5	49.4	64	340	750	91	200



### MD ADJUSTABLE PULLEY

Ideal for creating a wide range of progression programs including exercises that build upper body, lower body and core muscles • 35 clearly numbered adjustment points provide exercise variety • Low starting weight of 2.3 kg / 5 lbs. offers gradual progression • 1:2 pulley ratio provides smooth operation • Also available: optional incremental weight, balance bar, medical handrail, wheel transport and Inclusive Fitness kit

	PRODUCT DIMENSIONS (L X W X H)						PRODUCT WEIGHT		WEIGHT STACK	
	CM		INCHES				KG	LBS	KG	LBS
<b>MD-AP</b>	107.2	125	228	42.2	49.3	89.8	174	384	68	150

\*Products shown with optional accessories.

# VERSA FUNCTIONAL TRAINER

The smart design of our functional trainer provides a remarkable range of exercise options in a space-saving footprint. Incremental weight adjustment and a 1:2 pulley ratio make it easy to control exercise intensity and create progressions right for everyone from deconditioned users to elite athletes. Everything about our functional trainer — from the multi-grip pull-up bar to the color-coded adjustment points to the professionally illustrated exercise placards — offers intuitive operation for users and trainers alike. Optional storage makes it easy to organize and stow accessories for instant access, and the completely enclosed design protects the unit's moving parts while creating a solid, cohesive aesthetic on your floor.



FTS18

FTS30

## FUNCTIONAL TRAINER

Multi-position pull-up handles for greater exercise variety • Fully-enclosed weight stacks protect the machine's internal components • Enhanced placards highlight targeted muscle groups and proper user positioning for a wide range of exercises • One-handed pulley adjustment offers easy operation • Frame guards protect against chips and scratches • Clearly indicated adjustments for ease of use • Compact design accommodates placement in spaces with ceilings as low as 2.4 m / 8' • 76 cm / 30" connection provides ample storage for functional training accessories or 46 cm / 18" connection to accommodate optional training handles • 1:2 pulley ratio provides smooth operation • Standard effective resistance 34 kg / 75 lbs. (per side)

### Optional:

- VS-VFT60 heavy stack for added 13.6 kg / 30 lbs. of resistance per side for 47.6 kg / 105 lbs. effective resistance
- Accessory: VS-FTHP handle package includes four training handles (v-bar, curl bar, ropes, ankle strap)
- VS-FTIW 2.3 kg / 5 lb. increment weight (effective resistance 1.1 kg / 2.5lb.)

	PRODUCT DIMENSIONS (L X W X H)					PRODUCT WEIGHT		WEIGHT STACK		
	CM		INCHES			KG	LBS	KG	LBS	
<b>VS-VFT-S18</b>	111.8	160.0	237.6	44.0	63	93.5	355	782	68	150
<b>VS-VFT-S30</b>	122.7	145.8	237.6	48.3	57.4	93.5	369	814	68	150
<b>VS-VFT-S18 + VS-VFT60</b>	111.8	160.0	237.6	44.0	63	93.5	409	902	95	210
<b>VS-VFT-S30 + VS-VFT60</b>	122.7	145.8	237.6	48.3	57.4	93.5	424	934	95	210

\*Accessories not included.

**VERSA STANDARD FRAME COLORS**



Iced Silver†



Black Glossy



Matte Black†



Lace White



Polarized Titanium

**VERSA UPHOLSTERY COLOR OPTIONS**



Black



Slate Blue

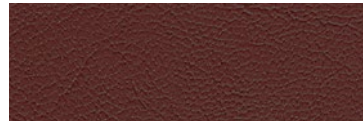

Clay Red



Graphite



Alloy

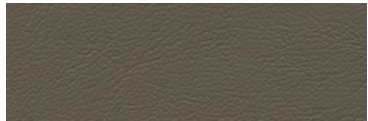

Hazelnut

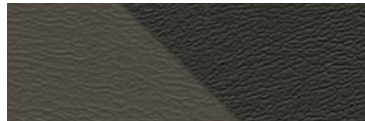

Alloy / Graphite

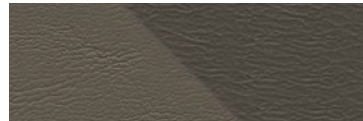

Hazelnut / Alloy



American Beauty



Candy Apple



New Burgundy



Paprika



Nasturtium



Mandarin Orange



Sun Yellow



Marigold



Emerald



Hunter Green



Royal Blue



Bluejay



Deep Violet



Navy



Bucksuede



Allspice



Cadet

Frame and upholstery colors applicable to the USA. Product pricing is reflective of **standard** upholstery only. Other color options available at an additional charge. NOTE: Actual product colors may vary from what is shown here. † Stocked frame color. Additional lead times may apply for other frame colors



# THE STANDARD IN PERFORMANCE AND DESIGN

## AURA SERIES

Superior styling made the Aura Series an instant classic. Signature features made it one of the most-imitated product lines in the industry. Choose the Aura Series, and you'll discover that beginners and fitness enthusiasts alike will be drawn to something that the competition can't imitate — an unmistakable aura of greatness.





20 lbs	9 kg
30 lbs	14 kg
40 lbs	18 kg
50 lbs	23 kg
60 lbs	27 kg
70 lbs	32 kg
80 lbs	36 kg
90 lbs	41 kg
100 lbs	45 kg
110 lbs	50 kg
120 lbs	54 kg
130 lbs	59 kg
140 lbs	64 kg
150 lbs	68 kg
160 lbs	73 kg
170 lbs	77 kg
180 lbs	82 kg
190 lbs	86 kg
200 lbs	91 kg

# AURA SERIES

A superior blend of features and sophistication, the Aura Series appeals to fitness enthusiasts of all kinds. Independent converging and diverging motions on select units provide a natural resistance movement that feels smooth and natural. Ergo Form™ cushions ensure proper body alignment and support while introducing an extra touch of style. In addition to offering a unique aesthetic distinction that attracts users, our round-tube construction with automotive-quality powder-coat finish provides lasting strength and durability.



**FRAME AND FINISH**

Attractive round-tube construction provides unmatched strength, and automotive-quality finish is highly resistant to chips and scratches.

**ERGO FORM CUSHIONS**

Uniquely attractive design ensures proper body alignment and support.

**INCREMENTAL WEIGHTS**

Easy to access and reference from the seated position.

**CONVERGING/DIVERGING MOTION**

Encourages a natural path of motion to enhance comfort.

**BOTTLE AND TOWEL HOLDER**

Conveniently positioned to prevent spills and clutter on your floor.

**COLOR-CODED EXERCISE PLACARDS**

Easy-to-read reference cards highlight targeted muscle groups and proper machine use.





### CHEST PRESS

Adjustable pressing arm allows users to determine their own range of motion • Oversized, dual-position hand grips provide greater comfort and variety

	PRODUCT DIMENSIONS (L X W X H)						PRODUCT WEIGHT		WEIGHT STACK	
	CM		INCHES				KG	LBS	KG	LBS
<b>G3-S10</b>	127	155.9	184.7	50	61.4	72.7	275	607	113	250



### PECTORAL FLY

Dual hand grips accommodate users of all sizes • Independent arm action ensures more balanced exercise by not allowing the dominant side to control the exercise • Adjustable starting position allows for greater range of motion

	PRODUCT DIMENSIONS (L X W X H)						PRODUCT WEIGHT		WEIGHT STACK	
	CM		INCHES				KG	LBS	KG	LBS
<b>G3-S12</b>	113.3	156.8	150.6	44.6	61.7	59.3	246	542	91	200



### CONVERGING CHEST PRESS

Independent converging motion arms • Dual hand-grip positions provide greater training variety • Designed for easy entry and exit

	PRODUCT DIMENSIONS (L X W X H)						PRODUCT WEIGHT		WEIGHT STACK	
	CM		INCHES				KG	LBS	KG	LBS
<b>G3-S13</b>	128.3	155.1	174.8	50.5	61.1	68.8	293	645	113	250



### SHOULDER PRESS

Dual-position hand grips allow for greater training variety • Oversized hand grips provide improved function and comfort • Counterbalanced pressing arm provides reduced starting resistance

	PRODUCT DIMENSIONS (L X W X H)						PRODUCT WEIGHT		WEIGHT STACK	
	CM		INCHES				KG	LBS	KG	LBS
<b>G3-S20</b>	152	146.9	150.7	59.8	57.8	59.3	251	553	91	200



### LATERAL RAISE

Independent arm action ensures balanced exercise • Handles pivot to accommodate users of all sizes

	PRODUCT DIMENSIONS (L X W X H)						PRODUCT WEIGHT		WEIGHT STACK	
	CM		INCHES				KG	LBS	KG	LBS
<b>G3-S21</b>	154.2	152.4	150.6	60.7	60	59.3	271	597	91	200



### REAR DELT / PEC FLY

User arms pivot to accommodate individual forearm lengths and varying paths of motion • Optimized handle positions reduce the need to adjust the seat position between rear deltoid and fly exercises

	PRODUCT DIMENSIONS (L X W X H)						PRODUCT WEIGHT		WEIGHT STACK	
	CM		INCHES				KG	LBS	KG	LBS
<b>G3-S22</b>	189	195.5	205	74.5	77	81	288.5	636	134	295



### CONVERGING SHOULDER PRESS

Independent converging motion arms • Pressing arm includes both standard and neutral grips for user preference • Oversized hand grips provide greater comfort and variety

	PRODUCT DIMENSIONS (L X W X H)						PRODUCT WEIGHT		WEIGHT STACK	
	CM		INCHES				KG	LBS	KG	LBS
<b>G3-S23</b>	153.8	149.3	173.6	60.6	58.8	68.4	251	553	91	200



### LAT PULLDOWN

Thigh pads easily adjust to provide both stability and comfort • Straight bar with angled ends ensures correct arm and wrist position throughout the entire range of motion

	PRODUCT DIMENSIONS (L X W X H)						PRODUCT WEIGHT		WEIGHT STACK	
	CM		INCHES				KG	LBS	KG	LBS
<b>G3-S30</b>	139.5	120	221.5	55	47	87	245	540	134	295



### SEATED ROW

Dual-position hand grips allow for greater training variety • Optimized pivot location creates a biomechanically correct arc of motion

	PRODUCT DIMENSIONS (L X W X H)						PRODUCT WEIGHT		WEIGHT STACK	
	CM		INCHES				KG	LBS	KG	LBS
<b>G3-S31</b>	151.4	92.1	210.6	59.6	36.3	82.9	273	601	113	250



### DIVERGING LAT PULLDOWN

Independent diverging motion arms • Angled seat cues optimal user position • High pads easily adjust to provide both stability and comfort

	PRODUCT DIMENSIONS (L X W X H)						PRODUCT WEIGHT		WEIGHT STACK	
	CM		INCHES				KG	LBS	KG	LBS
<b>G3-S33</b>	146.7	88.4	211.7	57.8	34.8	83.3	237	527	113	250



### DIVERGING SEATED ROW

Independent diverging motion arms • Dual-position hand grips provide greater training variety

	PRODUCT DIMENSIONS (L X W X H)						PRODUCT WEIGHT		WEIGHT STACK	
	CM			INCHES			KG	LBS	KG	LBS
<b>G3-S34</b>	154.4	87.9	198.7	60.8	34.6	78.2	259	570	113	250



### ARM CURL

Arm pad is angled for stability and limits unwanted shoulder movement during exercise • Angled rotating hand grips ensure optimal wrist position

	PRODUCT DIMENSIONS (L X W X H)						PRODUCT WEIGHT		WEIGHT STACK	
	CM			INCHES			KG	LBS	KG	LBS
<b>G3-S40</b>	122.2	108.6	150.6	48.1	42.8	59.3	228	502	91	200



### TRICEPS PRESS

Rotating handles adapt to users of all sizes • Over-molded grips ensure a secure, non-slip feel • Angled back pad reduces stress, improves stabilization and enhances comfort

	PRODUCT DIMENSIONS (L X W X H)						PRODUCT WEIGHT		WEIGHT STACK	
	CM		INCHES				KG	LBS	KG	LBS
<b>G3-S42</b>	158.8	128	173.6	62.5	50.4	68.4	261	575	91	200



### TRICEP EXTENSION

Seat and upper-arm pads are angled to enhance user stability during exercise • Handle pivots adjust for varying forearm lengths

	PRODUCT DIMENSIONS (L X W X H)						PRODUCT WEIGHT		WEIGHT STACK	
	CM		INCHES				KG	LBS	KG	LBS
<b>G3-S45</b>	117.4	108.4	150.6	46.2	42.7	59.3	223	491	91	200



### ABDOMINAL CRUNCH

Dual axis of rotation enhances user feel for a natural crunch movement and muscle contraction • Seat and handle positions enhance user stability

	PRODUCT DIMENSIONS (L X W X H)					PRODUCT WEIGHT		WEIGHT STACK		
	CM		INCHES			KG	LBS	KG	LBS	
<b>G3-S51</b>	142.8	112.2	150.5	56.2	44.2	59.3	184	405	91	200



### BACK EXTENSION

Adjustable nonskid footrests provide secure and proper positioning • Lower-back reference pad encourages proper user alignment

	PRODUCT DIMENSIONS (L X W X H)					PRODUCT WEIGHT		WEIGHT STACK		
	CM		INCHES			KG	LBS	KG	LBS	
<b>G3-S52</b>	157.7	106.5	174.9	62.1	41.9	68.9	277	610	134	295



### ROTARY TORSO

Unique design reinforces proper user positioning • Range of motion is adjustable in 10-degree increments • Foot bar helps users of all sizes achieve proper stabilization

	PRODUCT DIMENSIONS (L X W X H)						PRODUCT WEIGHT		WEIGHT STACK	
	CM		INCHES				KG	LBS	KG	LBS
<b>G3-S55</b>	164.2	97	173.7	64.6	38.2	68.4	216	476	91	200



### DIP / CHIN ASSIST

Rotating dip handles adapt to users of all sizes • Pull-up bar offers both standard and neutral grips for individual preference • 2 sets of pull-up grips allow users of all heights a full range of motion

	PRODUCT DIMENSIONS (L X W X H)						PRODUCT WEIGHT		WEIGHT STACK	
	CM		INCHES				KG	LBS	KG	LBS
<b>G3-S60</b>	127	106.5	231.5	50	42	91	197	434	70.3	155





### LEG PRESS

4-bar linkage enhances alignment and provides variable resistance • Large nonskid footplate accommodates users of all sizes

	PRODUCT DIMENSIONS (L X W X H)						PRODUCT WEIGHT		WEIGHT STACK	
	CM		INCHES				KG	LBS	KG	LBS
<b>G3-S70</b>	210.1	124.6	184.6	82.7	49	72.7	417	920	175	385



### LEG EXTENSION

Angled seat and back pads encourage full quadriceps contraction • Adjustable start position facilitates increased range of motion • Self-adjusting tibia pad enhances comfort

	PRODUCT DIMENSIONS (L X W X H)						PRODUCT WEIGHT		WEIGHT STACK	
	CM		INCHES				KG	LBS	KG	LBS
<b>G3-S71</b>	180.5	111.5	175	71	44	69	245.5	542	113	250



### SEATED LEG CURL

Seat, back and tibia pads adjust without affecting knee alignment or start-position angle • Adjustable start position facilitates increased range of motion

	PRODUCT DIMENSIONS (L X W X H)					PRODUCT WEIGHT		WEIGHT STACK		
	CM	INCHES		KG	LBS	KG	LBS			
<b>G3-S72</b>	180	108	174.5	71	42.5	68.75	248.5	548	93	205



### PRONE LEG CURL

Divergent pad angle eliminates lower-back stress • Standard range of motion adjusts for individual preference

	PRODUCT DIMENSIONS (L X W X H)					PRODUCT WEIGHT		WEIGHT STACK		
	CM	INCHES		KG	LBS	KG	LBS			
<b>G3-S73</b>	171	111	174.5	67.5	44	68.75	222	489.5	91	200



### HIP ADDUCTOR

Knee pads and dual footrests provide leg support and enhanced comfort • Weight stack positioned in front of the user acts as a shield, providing enhanced privacy

	PRODUCT DIMENSIONS (L X W X H)						PRODUCT WEIGHT		WEIGHT STACK	
	CM		INCHES				KG	LBS	KG	LBS
<b>G3-S74</b>	166.6	164.3	150.8	65.6	64.7	59.4	264	582	100	220



### HIP ABDUCTOR

Knee pads and dual footrests provide leg support to eliminate unwanted torque around the knee • Weight stack positioned in front of the user acts as a shield, providing enhanced privacy

	PRODUCT DIMENSIONS (L X W X H)						PRODUCT WEIGHT		WEIGHT STACK	
	CM		INCHES				KG	LBS	KG	LBS
<b>G3-S75</b>	166.6	107.5	150.8	65.6	42.3	59.4	270	595	100	220



## ROTARY HIP

Standing position provides enhanced alignment and increased target muscle involvement • Adjustable carriage allows users of varying heights to achieve optimal positioning • Starting positions are incremental at 15-degree intervals through 270 degrees of rotation • Low step-up height 13.2 cm / 5.2" for easy entry and exit

	PRODUCT DIMENSIONS (L X W X H)						PRODUCT WEIGHT		WEIGHT STACK	
	CM		INCHES				KG	LBS	KG	LBS
<b>G3-S76</b>	111.7	119.7	184.3	44	47.1	72.6	295	650	134	295



## CALF PRESS

Force is transmitted through hips to eliminate spinal compression • Foot plates are curved for comfortable positioning and a full range of motion • Fully enclosed linear bearings provide smooth, quiet motion

	PRODUCT DIMENSIONS (L X W X H)						PRODUCT WEIGHT		WEIGHT STACK	
	CM		INCHES				KG	LBS	KG	LBS
<b>G3-S77</b>	173	68.9	150.5	68.1	27.1	59.3	304	670	134	295



## FUNCTIONAL TRAINER

1:4 pulley ratio offers low starting resistance and high-speed movements • Available with 131-kg / 290-lb. or 177-kg / 390-lb. stacks • Standard swiveling accessory station includes 10 attachments • Multi-grip-position pull-up handles with unique rock-climbing attachment • Integrated fold-away step offers easy access • G3-MSFT300 effective resistance: 32.9-kg / 72.5-lbs. (per side) • G3-MSFT400 effective resistance: 44.2-kg / 97.5-lbs. (per side)

	PRODUCT DIMENSIONS (L X W X H)						PRODUCT WEIGHT		WEIGHT STACK	
	CM		INCHES				KG	LBS	KG	LBS
<b>G3-MSFT300</b>	169.2	130.2	234.4	66.6	51.2	92.3	601	1324	2 X 131	2 X 290
<b>G3-MSFT400</b>	169.2	130.2	234.4	66.6	51.2	92.3	697	1537	2 X 177	2 X 390



Flanged pulley housing

### ADJUSTABLE CABLE CROSSOVER

Widely spaced, dual-adjustable pulleys offer exercise variety • Pull-up bar with both lat and neutral grips provide hand placement options • One-handed adjustment makes operation easy • Flanged pulley housing minimizes cable wear and increases durability • 1:2 pulley ratio provides smooth operation



	PRODUCT DIMENSIONS (L X W X H)						PRODUCT WEIGHT		WEIGHT STACK	
	CM		INCHES				KG	LBS	KG	LBS
<b>G3-MS20</b>	397.4	90	239.6	156.5	35.4	94.3	399	880	2 X 91	2 X 200

# AURA

## MULTI-STATION: PRECONFIGURED



### 8-STACK MULTI-STATION

	PRODUCT DIMENSIONS (L X W X H)					PRODUCT WEIGHT		WEIGHT STACK		
	CM	INCHES				KG	LBS	KG	LBS	
<b>G3-MS80</b>	561.3	370.9	251.7	221	146	99.1	1996	4400	4 X 91 4 X 134	4 X 200 4 X 295



**4-STACK MULTI-STATION**

	PRODUCT DIMENSIONS (L X W X H)						PRODUCT WEIGHT		WEIGHT STACK	
	CM		INCHES				KG	LBS	KG	LBS
<b>G3-MS40</b>	167.8	369.8	252	66.1	145.6	99.2	998	2200	2 X 91 2 X 134	2 X 200 2 X 295



**5-STACK MULTI-STATION**

	PRODUCT DIMENSIONS (L X W X H)						PRODUCT WEIGHT		WEIGHT STACK	
	CM		INCHES				KG	LBS	KG	LBS
<b>G3-MS50</b>	481.5	369.8	251.7	189.6	145.6	99.1	1197	2640	3 X 91 2 X 134	3 X 200 2 X 295

# AURA

# MULTI-STATION: CONFIGURE YOUR OWN

Meet the strength training needs of multiple users and maximize training options with the completely customizable Aura Multi-Stations. Create your own combination of the Lat Pulldown (MS51), Adjustable Pulley (MS24), Triceps Pressdown (MS52) and/or Low Row (MS53). One recent Matrix customer even created an impressive 28-stack unit that spans the entire length of their facility for unparalleled versatility and space efficiency.

All units include water bottle holders and towel hooks so essential accessories are easily accessible. In addition to offering a unique aesthetic distinction, our round-tube construction with an automotive-quality powder-coat finish provides lasting strength and durability.

## BLANK STATION

Enclosed panel for versatility and space configuration • Double shrouds with smooth edges



	PRODUCT DIMENSIONS (L X W X H)						PRODUCT WEIGHT	
		CM	INCHES		KG	LBS		
<b>G3-MS00</b>	67.5	34.5	240	26.5	13.5	94.5	57.5	127

### ADJUSTABLE PULLEY

Single-handed height adjustment offers easy use • 1:2 pulley ratio provides smooth movement and smaller incremental weight changes • Balance bar adds support during exercise • Combine with G3-MS24FS free-standing kit for stand-alone unit (bolt-down required)



	PRODUCT DIMENSIONS (L X W X H)						PRODUCT WEIGHT		WEIGHT STACK	
	CM		INCHES				KG	LBS	KG	LBS
<b>G3-MS24</b>	68	70	240	27	28	94.5	181	398.5	91	200

### LAT PULLDOWN

Two independent cables add training variety • Angled knee pad allows for quick and easy adjustments



	PRODUCT DIMENSIONS (L X W X H)						PRODUCT WEIGHT		WEIGHT STACK	
	CM		INCHES				KG	LBS	KG	LBS
<b>G3-MS51</b>	140	120	252	55	47	99.5	252	556	134	295

### TRICEPS PRESSDOWN

Swiveling top pulley enhances durability • 1:1 pulley ratio allows for heavy training • Additional stability pad enhances comfort



	PRODUCT DIMENSIONS (L X W X H)						PRODUCT WEIGHT		WEIGHT STACK	
	CM		INCHES				KG	LBS	KG	LBS
<b>G3-MS52</b>	85	59	240	33.5	23.5	94.5	171.5	377.5	91	200

### LOW ROW

Two independent cables add training variety • Durable rubber platform protects frame and handles from damage • Large foot platform allows for variety in foot placement.



	PRODUCT DIMENSIONS (L X W X H)						PRODUCT WEIGHT		WEIGHT STACK	
	CM		INCHES				KG	LBS	KG	LBS
<b>G3-MS53</b>	230	71	240	91	28	94.5	260	573	134	295

## AURA STANDARD FRAME COLORS



Iced Silver†



Black Glossy



Matte Black†

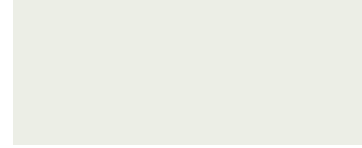

Lace White



Polarized Titanium

## AURA UPHOLSTERY COLOR OPTIONS



Black



Slate Blue

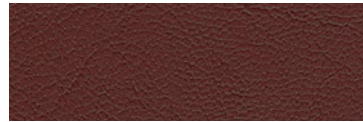

Clay Red



Graphite



Alloy

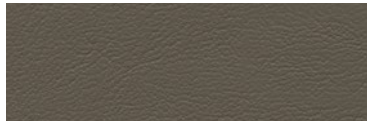

Hazelnut

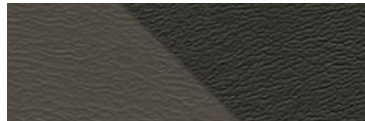

Alloy / Graphite



Hazelnut / Alloy



American Beauty



Candy Apple



New Burgundy



Paprika



Nasturtium



Mandarin Orange



Sun Yellow



Marigold



Emerald



Hunter Green



Royal Blue



Bluejay



Deep Violet



Navy



Bucksuede



Allspice



Cadet

Frame and upholstery colors applicable to the USA. Product pricing is reflective of **standard** upholstery only. Other color options available at an additional charge.  
 NOTE: Actual product colors may vary from what is shown here. † Stocked frame color. Additional lead times may apply for other frame colors



# DISCOVER THE STRENGTH OF SIMPLICITY

## GO SERIES

Ideal for users new to strength training and circuit programs, Go Series single stations are compact and easy-to-use — creating a welcoming experience. Go Series features back-to-back design, improving traffic flow and making it easy to configure your space. Each single-station unit has a low starting weight and minimal to no adjustments, so users can get started right away.





SEAT  
TRICEPS

40 18  
50 22.5  
60 27  
70 31.5  
80 36  
90 40.5  
45

120  
160 72

# GO SERIES

## ENHANCED USABILITY

Minimal adjustments, low starting weight and optional incremental weight allows for smaller progressions that keep users of all abilities motivated as they gain strength.

## SPACE-SAVING DESIGN

Compact footprint with back-to-back configurations improves traffic flow and helps you serve more users when space is at a premium and budgets need to stretch further.

## STREAMLINED SERVICE & MAINTENANCE

Guide rods can be removed without any tools, while a durable metal shroud withstands tough environments and can be easily removed to streamline service.

## USER AMENITIES

Storage space on top of stack lets users keep their personal device, water bottle and towel in reach while reducing clutter on your floor.

## EXERCISE PLACARDS

Large, easy-to-read reference cards highlight targeted muscle groups and proper machine use.

## INCREMENTAL WEIGHTS

An optional 2.3-kg / 5-lb. incremental weight allows for smaller progressions that keep users motivated as they gain strength.



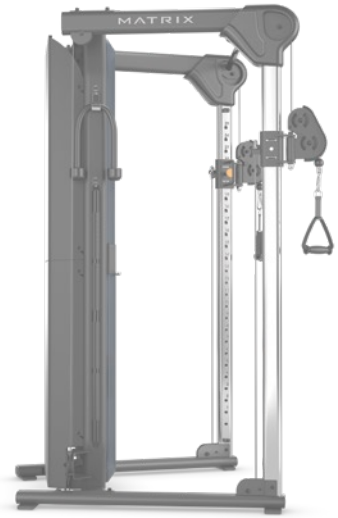



### CHEST PRESS

Oversized neutral grips provide a natural, comfortable hold that reduces stress on shoulder joints • Intuitive design with no adjustments needed

	PRODUCT DIMENSIONS (L X W X H)						PRODUCT WEIGHT		WEIGHT STACK	
	CM			INCHES			KG	LBS	KG	LBS
<b>GO-S13</b>	158	118	137	62.2	46.6	54	166	366	72	160



### SHOULDER PRESS

Intuitive design with no adjustments needed • Oversized neutral grips provide a natural, comfortable hold that reduces stress on shoulder joints

	PRODUCT DIMENSIONS (L X W X H)						PRODUCT WEIGHT		WEIGHT STACK	
	CM			INCHES			KG	LBS	KG	LBS
<b>GO-S23</b>	148	110.5	176	58.4	43.5	69.3	160	353	45	100



### LAT PULLDOWN

Ratcheting seat adjusts easily, letting users fine tune the range of motion for optimal comfort and function • Oversized neutral grips offer a comfortable hold while reducing stress on shoulder joints

	PRODUCT DIMENSIONS (L X W X H)						PRODUCT WEIGHT		WEIGHT STACK	
	CM		INCHES				KG	LBS	KG	LBS
<b>GO-S33</b>	174	91	171	68.5	35.8	67.3	210	463	72	160



### SEATED ROW

Oversized angled grips provide a natural, comfortable hold • Dual position foot pegs and an extra-long seat let users of different heights position themselves comfortably with no adjustments needed

	PRODUCT DIMENSIONS (L X W X H)						PRODUCT WEIGHT		WEIGHT STACK	
	CM		INCHES				KG	LBS	KG	LBS
<b>GO-S34</b>	148	123	137	58.3	48.5	54	159	350.5	72	160



### BICEPS CURL

Intuitive design with no adjustments needed • Highlighted pivot point indicates optimal elbow positioning and body alignment • Extended seat lets users shift hip positioning for proper alignment

	PRODUCT DIMENSIONS (L X W X H)						PRODUCT WEIGHT		WEIGHT STACK	
	CM			INCHES			KG	LBS	KG	LBS
<b>GO-S40</b>	125	104	137	49.2	41	54	148	326.5	54	120



### SEATED TRICEPS PRESS

Oversized neutral grips provide a natural, comfortable hold • Seated press motion follows a natural path, reducing stress on elbow joints, engaging the entire upper body and aiding in sit-to-stand progressions • Intuitive design with no adjustments needed

	PRODUCT DIMENSIONS (L X W X H)						PRODUCT WEIGHT		WEIGHT STACK	
	CM			INCHES			KG	LBS	KG	LBS
<b>GO-S42</b>	130.5	101.5	137	51.4	39.9	54	163	359.5	72	160



### ABDOMINAL

Intuitive design with no adjustments needed • Comfortably contoured back pad provides a full range of motion, stretching core muscles in a way traditional flat back pads can't • Soft, oversized grips offer a comfortable hold

	PRODUCT DIMENSIONS (L X W X H)						PRODUCT WEIGHT		WEIGHT STACK	
	CM		INCHES				KG	LBS	KG	LBS
<b>GO-S53</b>	158	94.5	137	62.2	37.2	54	150.5	332	63	140



### LEG PRESS

Low step-in height offers easy entry and exit • Clearly numbered adjustment points make each user's starting point easily identifiable and repeatable for faster starts • Large rubber foot platform with a textured surface offers comfortable, secure foot placement for a wide range of users

	PRODUCT DIMENSIONS (L X W X H)						PRODUCT WEIGHT		WEIGHT STACK	
	CM		INCHES				KG	LBS	KG	LBS
<b>GO-S70</b>	101	183.5	137	39.7	72.3	54	246	542.4	95	210



## LEG EXTENSION

Extra-large seat offers comfortable support for users and faster transitions in and out of the unit • Self-adjusting tibia pad provides greater ease of use • Adjustable range of motion lets users with different degrees of knee mobility build strength

	PRODUCT DIMENSIONS (L X W X H)						PRODUCT WEIGHT		WEIGHT STACK	
	CM		INCHES				KG	LBS	KG	LBS
<b>GO-S71</b>	132	130	137	52	51.3	54	178	392.5	72	160



## SEATED LEG CURL

Self-adjusting ankle pad provides greater ease of use • Adjustable range of motion lets users with different degrees of hamstring mobility build strength • Extra-large seat offers comfortable support for users and faster transitions in and out of the unit

	PRODUCT DIMENSIONS (L X W X H)						PRODUCT WEIGHT		WEIGHT STACK	
	CM		INCHES				KG	LBS	KG	LBS
<b>GO-S72</b>	128	109	137	50.5	43	54	198	436.5	54	120



### ADJUSTABLE BENCH

Five different back pad angle adjustments (0°, 30°, 45°, 60°, and 75°), and 2 seat pad angle adjustments (0°, and 20%) move effortlessly to help target specific muscles and provide excellent stability during diverse exercises • An integrated exercise band attachment point accommodates elastic exercises • Space-saving vertical storage configuration • Built-in wheels and an ergonomic handle for convenient transport

	PRODUCT DIMENSIONS (L X W X H)						PRODUCT WEIGHT	
	CM	INCHES				KG	LBS	
<b>GO-AB</b>	142.4	77.5	43.7	56	30.5	17.25	36	79.5



### FUNCTIONAL TRAINER

Variable pulley ratio technology lets users train for maximum strength or focus on explosive, athletic movements • 25 height positions offers a virtually endless variety of exercises • Compact footprint helps you serve more users when space is at a premium • A low overall height makes it easy to fit into facilities with lower ceilings • Enclosed adjustment handle provides a safe and secure location to attach exercise bands for elastic training • Also available: Optional Handle Package (GO-FTHP)

	PRODUCT DIMENSIONS (L X W X H)						PRODUCT WEIGHT		WEIGHT STACK	
	CM	INCHES				KG	LBS	KG	LBS	
<b>GO-FT3</b>	129.5	137.5	212	51	54	83.5	246.5	543.4	136	300
<b>GO-FT4</b>	129.5	137.5	212	51	54	83.5	292	643.4	180	400

**GO SERIES STANDARD FRAME COLORS**



Iced Silver†



Black Glossy



Matte Black



Lace White



Polarized Titanium

**GO SERIES UPHOLSTERY COLOR OPTIONS**

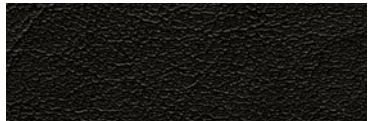

Black



Slate Blue

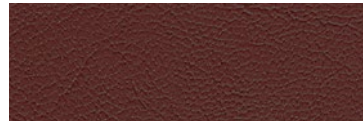

Clay Red

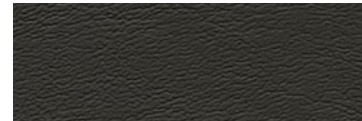

Graphite



Alloy

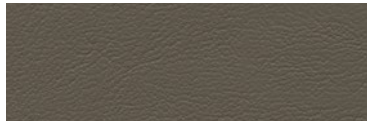

Hazelnut



Alloy / Graphite

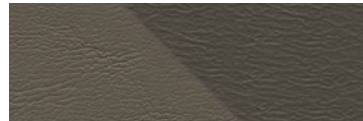

Hazelnut / Alloy



American Beauty



Candy Apple



New Burgundy



Paprika



Nasturtium



Mandarin Orange



Sun Yellow



Marigold



Emerald



Hunter Green



Royal Blue



Bluejay



Deep Violet



Navy



Bucksuede



Allspice



Cadet

Frame and upholstery colors applicable to the USA. Product pricing is reflective of **standard** upholstery only. Other color options available at an additional charge. NOTE: Actual product colors may vary from what is shown here. † Stocked frame color. Additional lead times may apply for other frame colors



# A LEGACY OF PERFORMANCE AND PROVEN DURABILITY

## MAGNUM SERIES

Ideal for helping serious strength trainers reach their ultimate potential, the Magnum Series provides an unparalleled blend of performance and durability. Simple, exclusive Breaker Benches allow users to get into the start position with less stress on their joints. Other products like MX Racks pack in the functionality to help you make the most of your floor space. Best of all, everything that carries the Magnum Series name will withstand the most intense training environments.

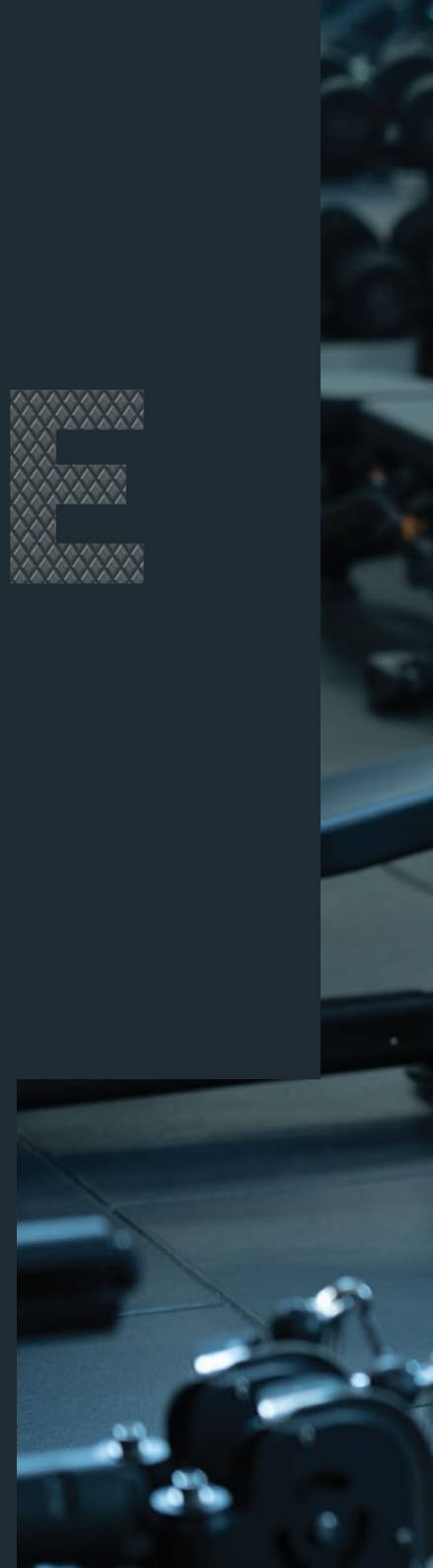



# MAGNUM SERIES

## **ERGONOMICS AND BIOMECHANICS**

Designed for comfort while providing a natural, mechanically correct motion.

## **DURABLE CONSTRUCTION**

Originally built to withstand the rigorous strength training of professional sports teams.

## **FRAME FINISH**

Automotive-quality finish is highly resistant to chips and scratches.

## **CONVERGING/DIVERGING MOTION**

Encourages a natural path of motion to enhance comfort.

## **COLOR-CODED ADJUSTMENT POINTS**

Conveniently located and clearly marked for easy use.

## **EQUIPMENT VARIETY**

A robust selection meets the training needs of virtually any facility.



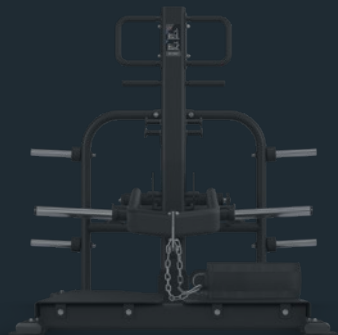

MAGNUM BREAKER BENCHES /

# EASIER TAKEOFFS

Incredibly beneficial for beginners and professional athletes alike, this exclusive system uses pivoting uprights to place the bar directly over the user. We call them Breaker Benches because they eliminate the need for assistance to break the bar, allowing users to get into the start position with less stress on their joints. Greater comfort, easier takeoffs and increased efficiency add up to a superior solution for all users in resistance training.

All equipment is designed & tested to meet EN957 and ASTM safety standards.





### BREAKER OLYMPIC FLAT BENCH

Uprights pivot forward into ideal starting position, directly over the user for easy takeoff • Molded urethane guards protect Olympic bars from damage, reduce noise and provide a hand rest for spotters • Wide back pad stabilizes users during heavy lifts • 10 optional weight-storage horns (20-kg / 45-lb. plates store at waist height)

	PRODUCT DIMENSIONS (L X W X H)						PRODUCT WEIGHT	
	CM		INCHES				KG	LBS
<b>MG-A678</b>	173	168	130	68	66	51	94	207



### OLYMPIC FLAT BENCH

Molded urethane guards protect Olympic bars from damage, reduce noise and provide a hand rest for spotters • Wide back pad stabilizes users during heavy lifts • 10 optional weight-storage horns (20-kg / 45-lb. plates store at waist height) • Shown with optional spotter platform (MG-AOSP)

	PRODUCT DIMENSIONS (L X W X H)						PRODUCT WEIGHT	
	CM		INCHES				KG	LBS
<b>MG-A78</b>	163	168	130	64	66	51	73	160



### BREAKER OLYMPIC INCLINE BENCH

Uprights pivot forward into ideal starting position, directly over the user for easy takeoff • Molded urethane guards protect Olympic bars from damage, reduce noise and provide a hand rest for spotters • Wide back pad stabilizes users during heavy lifts • Ratcheting seat design for ease of use and adjustment • 10 optional weight-storage horns (20-kg / 45-lb. plates store at waist height) • Comes standard with built-in spotter platform

	PRODUCT DIMENSIONS (L X W X H)						PRODUCT WEIGHT	
	CM		INCHES				KG	LBS
<b>MG-A679</b>	170	168	160	67	66	63	126	277



### OLYMPIC INCLINE BENCH

Molded urethane guards protect Olympic bars from damage, reduce noise and provide a hand rest for spotters • Wide back pad stabilizes users during heavy lifts • Ratcheting seat design for ease of use and adjustment • 10 optional weight-storage horns (20-kg / 45-lb. plates store at waist height) • Comes standard with built-in spotter platform

	PRODUCT DIMENSIONS (L X W X H)						PRODUCT WEIGHT	
	CM		INCHES				KG	LBS
<b>MG-A79</b>	170	168	160	67	66	63	107	235

## BREAKER OLYMPIC DECLINE BENCH



Uprights pivot forward into ideal starting position, directly over the user for easy takeoff • Molded urethane guards protect Olympic bars from damage, reduce noise and provide a hand rest for spotters • 10 optional weight-storage horns (20-kg / 45-lb. plates store at waist height) • Wide back pad stabilizes users during heavy lifts • Knee and ankle pads easily pivot to accommodate all user sizes

	PRODUCT DIMENSIONS (L X W X H)						PRODUCT WEIGHT	
	CM		INCHES				KG	LBS
<b>MG-A680</b>	206	168	135	81	66	53	107	235

## OLYMPIC DECLINE BENCH



Molded urethane guards protect Olympic bars from damage, reduce noise and provide a hand rest for spotters • 10 optional weight-storage horns (20-kg / 45-lb. plates store at waist height) • Wide back pad stabilizes users during heavy lifts • Knee and ankle pads easily pivot to accommodate all user sizes

	PRODUCT DIMENSIONS (L X W X H)						PRODUCT WEIGHT	
	CM		INCHES				KG	LBS
<b>MG-A80</b>	201	168	137	79	66	54	82	180

## BREAKER OLYMPIC SHOULDER BENCH



Uprights pivot forward into ideal starting position, directly over the user for easy takeoff • Molded urethane guards protect Olympic bars from damage, reduce noise and provide a hand rest for spotters • Comes standard with built-in spotter platform • 10 optional weight-storage horns (20-kg / 45-lb. plates store at waist height)

	PRODUCT DIMENSIONS (L X W X H)						PRODUCT WEIGHT	
	CM		INCHES				KG	LBS
<b>MG-A645</b>	135	138	183	53	66	72	118	260

## OLYMPIC SHOULDER BENCH



Front and rear takeoffs connected with bottom stop bar • Molded urethane guards protect Olympic bars from damage, reduce noise and provide a hand rest for spotters • Comes standard with built-in spotter platform • 10 optional weight-storage horns (20-kg / 45-lb. plates store at waist height)

	PRODUCT DIMENSIONS (L X W X H)						PRODUCT WEIGHT	
	CM		INCHES				KG	LBS
<b>MG-A45</b>	127	138	165	50	66	65	137	303



### 3-WAY OLYMPIC BENCH

Molded urethane guards protect Olympic bars from damage, reduce noise and provide a hand rest for spotters • Flat bench press, incline press and shoulder press can all be performed with simple adjustments • Easy-to-use seat automatically moves into proper position when back is adjusted • 10 weight-storage horns hold over 454 kg / 1000 lbs. of Olympic plates

	PRODUCT DIMENSIONS (L X W X H)						PRODUCT WEIGHT	
	CM		INCHES				KG	LBS
<b>MG-C895</b>	186.5	165	176.5	73.5	65	69.5	179.5	396



### OLYMPIC FLAT BENCH W/SAFETY ARMS

Multiple take-off heights accommodate users of all sizes • Ratcheting safeties provide a secure stop when needed • Tapered back pad maximizes stability • Molded urethane guards protect Olympic bars from damage, reduce noise and provide a hand rest for spotters

	PRODUCT DIMENSIONS (L X W X H)						PRODUCT WEIGHT	
	CM		INCHES				KG	LBS
<b>MG-A78S</b>	149	162.5	143	58.5	64	56.5	109.5	241.5





### BELT SQUAT

Continually controlled rack/unrack adjustment • Quick-connect belt squat attachment points • Varying-height multi-position grip handles • Upper- and lower-band attachment points • Oversized foot plates

	PRODUCT DIMENSIONS (L X W X H)						PRODUCT WEIGHT	
	CM			INCHES			KG	LBS
	CM	INCHES	CM	INCHES	CM	INCHES	KG	LBS
<b>MG-PL81</b>	198	152.5	152.5	78	60	60	242.8	535



### RECLINING LEG EXTENSION

Quadriceps-activating reclining seat • Five recline positions (50- 80 degrees). • Angled seat and back pads • Contoured knee pad • Band attachment points

	PRODUCT DIMENSIONS (L X W X H)						PRODUCT WEIGHT	
	CM			INCHES			KG	LBS
	CM	INCHES	CM	INCHES	CM	INCHES	KG	LBS
<b>MG-PL73</b>	173	155	124.5	68	61	49	156.4	345



### HIGH ROW

Rotating grip handles • Angled thigh pads • Footprint-reducing storage placement • Front vertical pulling design • Band attachment points

	PRODUCT DIMENSIONS (L X W X H)						PRODUCT WEIGHT	
	CM			INCHES			KG	LBS
	CM	INCHES	CM	INCHES	CM	INCHES	KG	LBS
<b>MG-PL37</b>	173	140	216	68	55	85	213.8	471.5



### T-BAR ROW

Non-slip oversized foot plates • Dual-grip handles  
 • Belt squat attachment • Attachment anchor for optional grips • Band attachment points

	PRODUCT DIMENSIONS (L X W X H)						PRODUCT WEIGHT	
	CM			INCHES			KG	LBS
	CM	INCHES	CM	INCHES	CM	INCHES	KG	LBS
<b>MG-PL35</b>	216	114.5	53.5	85	45	21	100	220



### INCLINE LEVER ROW

Neutral- and wide-grip handles • Multiple foot positions with a ratcheting foot platform • Floating or fixed handle locking mechanism • Core-stabilizing foot rest • Multiple take-off heights

	PRODUCT DIMENSIONS (L X W X H)						PRODUCT WEIGHT	
	CM			INCHES			KG	LBS
	CM	INCHES	CM	INCHES	CM	INCHES	KG	LBS
<b>MG-PL36</b>	211	120	121	83	47.25	47.5	110.5	244



### LOW ROW

Dual-grip handles • Space-saving, compact footprint • One-handed training vertical grip • Band attachment points

	PRODUCT DIMENSIONS (L X W X H)						PRODUCT WEIGHT	
	CM			INCHES			KG	LBS
	CM	INCHES	CM	INCHES	CM	INCHES	KG	LBS
<b>MG-PL38</b>	157.5	152.5	170	62	60	67	161	355



### PENDULUM SQUAT

Multi-angle adjustable, oversized foot platform • Range-controlling adjustable rear stop • Weight-reducing front counter balance • Height-accommodating racking positions • Footprint-reducing storage placement

	PRODUCT DIMENSIONS (L X W X H)						PRODUCT WEIGHT	
	CM			INCHES			KG	LBS
	<b>MG-PL80</b>	240	136	180	94.5	53	71	289.6



### KNEELING LEG CURL

Height-accommodating ankle pad adjustment • Pivoting knee pad • Contoured knee and forearm pads • Band attachment points

	PRODUCT DIMENSIONS (L X W X H)						PRODUCT WEIGHT	
	CM			INCHES			KG	LBS
	<b>MG-PL72</b>	127	140	129.5	50	55	51	134.9



### ELEVATED BICEPS CURL

Bicep-concentrated elevated pad position • High-weight capacity • Rotating grip handles • Band attachment points

	PRODUCT DIMENSIONS (L X W X H)						PRODUCT WEIGHT	
	CM			INCHES			KG	LBS
	<b>MG-PL41</b>	117	137	114.5	46	54	45	128.9



### STANDING HIP THRUST

Powerful combination of comfort, control and results • Non-slip oversized footplate • Multiple range of motion adjustments for a wide range of users • Varying-height multi-position grip handles

	PRODUCT DIMENSIONS (L X W X H)						PRODUCT WEIGHT	
	CM			INCHES			KG	LBS
	<b>MG-PL82</b>	119	127	157.5	46.75	50	62	104



### VERTICAL BENCH PRESS

Independent converging movement provides a natural path of motion • Back pad adjusts to alter range of motion and expand training options • Dual-grip pressing positions offer greater training variety • Ratcheting seat for easy adjustment • 4 integrated weight-storage horns

	PRODUCT DIMENSIONS (L X W X H)						PRODUCT WEIGHT	
	CM			INCHES			KG	LBS
	<b>MG-PL12</b>	146.5	168.5	199.5	58	66.5	78.5	196



### SUPINE BENCH PRESS

Independent converging movement provides a natural path of motion • Dual-grip pressing positions offer greater training variety • 2 integrated weight-storage horns

	PRODUCT DIMENSIONS (L X W X H)						PRODUCT WEIGHT	
	CM			INCHES			KG	LBS
	<b>MG-PL13</b>	184.5	127.5	89.5	72.5	50	35	99



### INCLINE BENCH PRESS

Independent converging movement provides a natural path of motion • Back pad adjusts to alter range of motion and expand training options • Dual-grip pressing positions offer greater training variety • Ratcheting seat for easy adjustment • 4 integrated weight-storage horns

	PRODUCT DIMENSIONS (L X W X H)						PRODUCT WEIGHT	
	CM		INCHES				KG	LBS
<b>MG-PL14</b>	208.2	143.2	129.6	82	56.5	51	147.5	325



### VERTICAL DECLINE BENCH PRESS

Independent converging movement provides a natural path of motion • Back pad adjusts to alter range of motion and expand training options • Dual-grip pressing positions offer greater training variety • Ratcheting seat for easy adjustment • 4 integrated weight-storage horns

	PRODUCT DIMENSIONS (L X W X H)						PRODUCT WEIGHT	
	CM		INCHES				KG	LBS
<b>MG-PL15</b>	148	168.5	195	58.5	66.5	77	195.5	431



### SHOULDER PRESS

Independent converging movement provides a natural path of motion • Slightly reclined position reduces lower back strain • Dual-grip pressing positions offer greater training variety • Ratcheting seat for easy adjustment • 4 integrated weight-storage horns

	PRODUCT DIMENSIONS (L X W X H)						PRODUCT WEIGHT	
	CM		INCHES				KG	LBS
<b>MG-PL23</b>	161.3	160	118.1	63.5	63	46.5	118	260



### LAT PULLDOWN

Diverging independent arms provide a natural path of motion • Easy-to-use thigh-pad adjustment for proper support • Angled seat cues optimal user position • 2 integrated weight-storage horns

MG-PL33	PRODUCT DIMENSIONS (L X W X H)						PRODUCT WEIGHT	
	CM			INCHES			KG	LBS
	182.9	123.2	190.5	72	48.5	75	128	282



### SEATED ROW

Diverging independent arms provide a natural path of motion • Dual-grip positions offer greater training variety • Two different foot positions accommodate a greater variety of user heights • Ratcheting seat for easy adjustment • Integrated weight-storage horn

MG-PL34	PRODUCT DIMENSIONS (L X W X H)						PRODUCT WEIGHT	
	CM			INCHES			KG	LBS
	152.4	139.7	106.7	60	55	42	118	260



### AB CRUNCH BENCH

Dual-supported pivot for added strength and performance • Lower step-through height for easy entry and exit • Dual-action pivot for natural biomechanics • Angled handles enhance shoulder comfort and feel • Center tube provides additional support • Weight horn accommodates 12-kg / 25-lb. plates for advanced users

MG-PL50	PRODUCT DIMENSIONS (L X W X H)					PRODUCT WEIGHT	
	CM		INCHES			KG	LBS
	162.6	88.9	100.3	64	35	39.5	60



### SMITH MACHINE

Counterbalanced 11.3-kg / 25-lb. bar takeoff for low starting resistance • Features a 90-degree path of motion adapts to all exercises • Linear bearings provide a smooth motion • Non-removable safety stops add training security • 8 integrated weight-storage horns hold multiple weight-plate sizes

MG-PL62	PRODUCT DIMENSIONS (L X W X H)						PRODUCT WEIGHT	
	CM			INCHES			KG	LBS
	110.5	231.1	245.1	43.5	91	96.5	270	569



### 45-DEGREE LEG PRESS

Easy-to-use and see racking mechanism • Adjustable bottom stops provide long or short ranges of motion for all user heights • Adjustable angle back pad enhances comfort, optimizes hip angles and accommodates a greater range of users • Assistance handle on platform for easier entry and exit • Linear bearings for smooth feel and function • 4 integrated weight-storage horns hold multiple weight-plate sizes

MG-PL70	PRODUCT DIMENSIONS (L X W X H)						PRODUCT WEIGHT	
	CM			INCHES			KG	LBS
	229	171	158	90	67.5	62.25	274	604



### GLUTE TRAINER

Comfortable user positioning mimics bar hip thrusting without the hassle of unwieldy free weights • Walk-through design with swiveling hip pad provides easy entry and exit • Band hooks provide elastic resistance for explosiveness training and movement variety • Floating hip pad adjusts to fit users of all sizes • Large, angled foot platform with non-slip surface offers excellent stability to better engage glutes

MG-PL78	PRODUCT DIMENSIONS (L X W X H)						PRODUCT WEIGHT	
	CM			INCHES			KG	LBS
	168	133	109	66.5	52.5	43	154	340



### HACK SQUAT

Large footplate and back pad accommodate users of all sizes • Spring-loaded take off handles for ease of use and engagement • Adjustable bottom stops provide long or short ranges of motion for all user heights • 4 integrated weight-storage horns

	PRODUCT DIMENSIONS (L X W X H)						PRODUCT WEIGHT	
	CM			INCHES			KG	LBS
	<b>MG-PL71</b>	228.2	150	144.6	90	59	57	270



### SQUAT / LUNGE

Independent lifting arms for balanced exercise and exercise variation • Multiple hand-grip positions offer greater training variety • 3 integrated weight-storage horns keep weight plates in close proximity • 4 user weight pegs provide maximal loading for strong users

	PRODUCT DIMENSIONS (L X W X H)						PRODUCT WEIGHT	
	CM			INCHES			KG	LBS
	<b>MG-PL79</b>	148.6	170.2	86.4	58.5	67	34	120



### STANDING CALF

Adjustable height shoulder pads accommodate users of all sizes • Angled footplate provides superior grip and improves calf recruitment • Angled support handles enhance comfort

	PRODUCT DIMENSIONS (L X W X H)						PRODUCT WEIGHT	
	CM			INCHES			KG	LBS
	<b>MG-PL76</b>	138	89	184.5	54.5	35	73	124



### SEATED CALF

Seat moves with input arm to maintain alignment • Curved and angled foot pad improves comfort and calf recruitment • Quick-release bar catch simplifies operation • Knee pads adjust for tibia length and range of motion

	PRODUCT DIMENSIONS (L X W X H)						PRODUCT WEIGHT	
	CM		INCHES				KG	LBS
<b>MG-PL77</b>	141	80	96.5	55.5	31.5	38	65	143.5



### REVERSE BACK EXTENSION

Adjustable starting point to select desired range of motion • Leg pad can be locked in forward position to use without resistance • Dual hand grips provide added variety and comfort • 2 weight-storage horns

	PRODUCT DIMENSIONS (L X W X H)						PRODUCT WEIGHT	
	CM		INCHES				KG	LBS
<b>MG-405</b>	150	109	145	59	43	57	134	295





### MULTI-ADJUSTABLE BENCH LP

Seat automatically adjusts with the back pad for ease of use • Adjustable back pad with 8 positions from 0 to 75 degrees • Tapered wide back pad stabilizes users during heavy lifts • Molded guards protect high wear / scuff areas • Transport handle and integrated wheels simplify movement within facility • Low 46 cm / 17.8" floor-to-pad height minimizes lower back stress and prevents arching

	PRODUCT DIMENSIONS (L X W X H)						PRODUCT WEIGHT	
	CM		INCHES				KG	LBS
<b>MG-A82</b>	152	78	46	59.7	30.6	17.8	55	121.5



### MULTI-ADJUSTABLE BENCH

Seat automatically adjusts with the back pad for ease of use • Adjustable back pad with 5 positions from 0 to 80 degrees • Wide back pad stabilizes users during heavy lifts • Molded guards protect high wear / scuff areas • Drop-away handle and integrated wheels simplify movement within facility

	PRODUCT DIMENSIONS (L X W X H)						PRODUCT WEIGHT	
	CM		INCHES				KG	LBS
<b>MG-A85</b>	135	58	51	53	23	20	43	95



### FLAT BENCH

Single cross leg provides more freedom for users • Wide back pad stabilizes users during heavy lifts • Molded guards protect high wear / scuff areas • Integrated wheels simplify movement within facility

	PRODUCT DIMENSIONS (L X W X H)						PRODUCT WEIGHT	
	CM		INCHES				KG	LBS
<b>MG-A59</b>	142	58	46	56	23	18	25	55



### MULTI-ADJUSTABLE BENCH W/DECLINE

Backrest adjusts into 7 positions — decline: 10 degrees; incline: 2.5, 17.5, 32, 48, 64.5 and 87.5 degrees • Wide back pad stabilizes users during heavy lifts • Molded guards protect high wear / scuff areas • Leg pads provide added stability • Integrated wheels simplify movement within facility

	PRODUCT DIMENSIONS (L X W X H)						PRODUCT WEIGHT	
	CM		INCHES				KG	LBS
<b>MG-A86</b>	166	60.5	53.5	65.25	23.75	21	62	137



### UTILITY BENCH

Oversized foot supports provide maximum stability • Molded guards protect high wear / scuff areas • Integrated wheels simplify movement within facility

	PRODUCT DIMENSIONS (L X W X H)						PRODUCT WEIGHT	
	CM		INCHES				KG	LBS
<b>MG-A87</b>	142	66	89	56	26	35	31	68



### ADJUSTABLE DECLINE BENCH

9 adjustments from 10 to 30 degrees • Gas-assist for easy adjustment • Wide back pad stabilizes users during heavy lifts • Molded guards protect high wear / scuff areas • Integrated wheels for easy transport

	PRODUCT DIMENSIONS (L X W X H)						PRODUCT WEIGHT	
	CM		INCHES				KG	LBS
<b>MG-A61</b>	163	64	81	64	25	32	45	99



### ADJUSTABLE AB BENCH

Adjustable leg pad accommodates all users • Molded guards protect high wear / scuff areas • Back support pivots into 6 different positions from 0 to 25 degrees • Elevated knee position reduces lower-back stress

	PRODUCT DIMENSIONS (L X W X H)						PRODUCT WEIGHT	
	CM		INCHES				KG	LBS
<b>MG-A77</b>	155	69	145	61	27	57	59	131



### GLUTE HAM BENCH

Step-through design • Leg pads and oversized footplate can be adjusted while in exercise position • Gas-assisted leg pad offers easy vertical adjustment • Handles to perform reverse hyperextensions • Hooks to attach bands for reverse hyperextensions

	PRODUCT DIMENSIONS (L X W X H)						PRODUCT WEIGHT	
	CM		INCHES				KG	LBS
<b>MG-A96</b>	157	91	130	62	36	51	136	300



### STANDING ARM CURL

Arm pad height adjusts to accommodate users of all sizes • Durable extruded guards protect frame and bar • Utilizing both sides of the machine increases functionality and saves space

	PRODUCT DIMENSIONS (L X W X H)						PRODUCT WEIGHT	
	CM		INCHES				KG	LBS
<b>MG-A71</b>	119	79	104	47	31	41	61	135



### PREACHER CURL

Angled, ratcheting seat encourages proper body positioning • Durable extruded guards protect frame and bar

	PRODUCT DIMENSIONS (L X W X H)						PRODUCT WEIGHT	
	CM		INCHES				KG	LBS
<b>MG-A62</b>	119	76	99	47	30	39	57	125



### VKR W/CHIN

Oversized round handles enhance comfort on dip • Angled back support, elbow pads and handles provide added stability and comfort • Multiple chin grips and rock-climbing grips add exercise variety

	PRODUCT DIMENSIONS (L X W X H)						PRODUCT WEIGHT	
	CM		INCHES				KG	LBS
<b>MG-A63C</b>	135	109	245	53	43	96	120	265



### SQUAT RACK

Fixed-bottom stops provide added security • Molded urethane guards protect Olympic bars from damage and reduce noise • 5 racking positions and 8 weight-storage horns are standard • Bottom stops can also be used to hold bar for various exercises • Safety distance from floor 71.75 cm / 28.25"

	PRODUCT DIMENSIONS (L X W X H)						PRODUCT WEIGHT	
	CM		INCHES				KG	LBS
<b>MG-A81</b>	211.5	166.8	201	83.3	67.5	79.2	125	275.6



### POWER STATION

Adjustable bar stop allows positioning from 30.5" to 48" • Fixed side frame is positioned at 20° for Olympic lifts • Eight racking positions accommodate users for any type of lift • Integrated pull-up bar for increased functionality • Six standard weight horns hold multiple weight plate sizes

	PRODUCT DIMENSIONS (L X W X H)						PRODUCT WEIGHT	
	CM		INCHES				KG	LBS
<b>MG-A73</b>	185.5	160.4	222.6	73	63.2	87.7	187.2	412.7



### BACK EXTENSION BENCH

Large thigh pads and skid-resistant foot platform for enhanced stability • Handles offer easy entry and exit • Molded guards protect high wear / scuff areas

	PRODUCT DIMENSIONS (L X W X H)						PRODUCT WEIGHT	
	CM		INCHES				KG	LBS
<b>MG-A52</b>	118.6	76.3	97.3	46.7	30	38.3	53	117



### MI BACK TRAINER

Large thigh pads and skid-resistant foot platform for enhanced stability • Handles offer easy entry and exit • Hooks to attach bands for added resistance • 3 different pad adjustment angles (55, 40, 25 degrees) • Gas-assist for easy adjustment

	PRODUCT DIMENSIONS (L X W X H)						PRODUCT WEIGHT	
	CM		INCHES				KG	LBS
<b>MD-FW52</b>	135.5	73.1	100.1	53.4	28.8	39.4	58	128



### PORTABLE SEAT

Provides a stable and supportive surface for resting between sets, while also helping to keep workout spaces organized and efficient • Convenient and comfortable place to sit • Compact, sturdy frame offers easy mobility

	PRODUCT DIMENSIONS (L X W X H)						PRODUCT WEIGHT	
	CM		INCHES				KG	LBS
<b>MG-A99</b>	65.5	52	50	26	20.5	20	12.5	27.6

## SPOTTER PLATFORM

Wide-tapered rubber platform provides additional leverage for heavy lifting • Available as an option on the MG-A78 and MG-A678 Olympic Flat Benches • Standard on the Olympic Incline and Shoulder Press Benches



	PRODUCT DIMENSIONS (L X W X H)						PRODUCT WEIGHT	
	CM		INCHES				KG	LBS
<b>MG-A0SP</b>	66	84	29	26	33	12	28	61

## HORIZONTAL PLATE RACK

Can hold a maximum of 314 kg / 693 lbs. in various weight plate configurations • Includes 1 horn to hold collars, and 1 Olympic bar storage horn • Integrated wheels for easy transport • Available in Ridge Black only



	PRODUCT DIMENSIONS (L X W X H)						PRODUCT WEIGHT	
	CM		INCHES				KG	LBS
<b>MG-A301</b>	160	38.1	43.2	63	15	17	24.9	54.9

## BARBELL RACK

Upright design provides convenience for barbell accessories • Rack holds 10 barbells, 5 per side • Chromed pegs provide lasting commercial finish



	PRODUCT DIMENSIONS (L X W X H)						PRODUCT WEIGHT	
	CM		INCHES				KG	LBS
<b>MG-A98</b>	138.5	88.7	152.9	54.5	34.9	60.2	81	178.6

## OLYMPIC WEIGHT TREE

9 chrome-plated storage horns for Olympic plates • Rubber bumpers on horns protect frame finish • Ergonomic design positions heavier plates further off the ground for easier removal and replacement



	PRODUCT DIMENSIONS (L X W X H)						PRODUCT WEIGHT	
	CM		INCHES				KG	LBS
<b>MG-A94</b>	87.1	57	107.9	34.3	22.5	42.5	28.8	63.5



### WEIGHT TREE W/BAR HOLDERS

6 chromed storage horns, 2 of which accommodate 20-kg / 45-lb. plates • 2 vertical bar holders for Olympic or curl bar storage • Rubber bumpers on horns protect frame finish

	PRODUCT DIMENSIONS (L X W X H)						PRODUCT WEIGHT	
	CM			INCHES			KG	LBS
<b>MG-A67B</b>	51	52	112	20	21	44	23	50



### ACCESSORY RACK

Facilitates placement of all accessories in one spot for convenience and a clutter-free facility • Top shelf holds additional accessories

	PRODUCT DIMENSIONS (L X W X H)						PRODUCT WEIGHT	
	CM			INCHES			KG	LBS
<b>MG-A97</b>	110.1	69.4	110.5	43.4	27.4	43.5	47.6	105

### 5-PAIR PRO-STYLE DUMBBELL RACK

Storage space for 5 pairs of pro-style dumbbells up to 68 kg / 150 lbs. • 15-degree angled tray helps prevent wrist strain when removing and replacing dumbbells • Cradles hold dumbbells securely in place to prevent rolling pinch hazards • Options available: decal sheet (MG-AODS); connector plate (MG-AOCP)



	PRODUCT DIMENSIONS (L X W X H)						PRODUCT WEIGHT	
	CM			INCHES			KG	LBS
<b>MG-A505</b>	232.6	61.3	79.8	91.6	24.2	31.5	63	138.6

### 10-PAIR PRO-STYLE DUMBBELL RACK

Storage space for 10 pairs of pro-style dumbbells up to 68 kg / 150 lbs. • 15-degree angled trays help prevent wrist strain when removing and replacing dumbbells • Cradles hold dumbbells securely in place to prevent rolling pinch hazards • Options available: decal sheet (MG-AODS); connector plate (MG-AOCP)



	PRODUCT DIMENSIONS (L X W X H)						PRODUCT WEIGHT	
	CM			INCHES			KG	LBS
<b>MG-A510</b>	232.6	61.3	79.8	91.6	24.2	31.5	106	233.2



### 15-PAIR PRO-STYLE DUMBBELL RACK

Storage space for 15 pairs of pro-style dumbbells up to 68 kg / 150 lbs. • 15-degree angled trays help prevent wrist strain when removing and replacing dumbbells • Cradles hold dumbbells securely in place to prevent rolling pinch hazards • Options available: decal sheet (MG-AODS); connector plate (MG-AOCP)

	PRODUCT DIMENSIONS (L X W X H)						PRODUCT WEIGHT	
	CM		INCHES				KG	LBS
<b>MG-A515</b>	232.6	67.3	102.1	91.6	26.5	40.2	156	343.2



### 2-TIER FLAT-TRAY DUMBBELL RACK

232 cm / 92" rack holds hex head dumbbells weighing up to 52 kg / 115 lbs. • Also available: 186 cm / 73", 2-tier Flat-tray Dumbbell Rack (MG-A526) • Options available: kettlebell storage insert (MG-AO15T for top tray, MG-AO15B for bottom tray); rubber mat insert (MG-AORM6 for MG-A526 dumbbell rack, MG-AORM8 for MG-A528 dumbbell rack); decal sheet (MG-AODS); connector plate (MG-AOCP)

	PRODUCT DIMENSIONS (L X W X H)						PRODUCT WEIGHT	
	CM		INCHES				KG	LBS
<b>MG-A528</b>	232.2	62.5	79.4	91.5	24.6	31.3	127	279.4
<b>MG-A526</b>	186.2	62.5	79.4	73.3	24.6	31.3	108	237.6



### 3-TIER FLAT-TRAY DUMBBELL RACK

232 cm / 92" rack holds hex head dumbbells weighing up to 52 kg / 115 lbs. • Also available: 186 cm / 73", 3-tier Flat-tray Dumbbell Rack (MG-A536) • Options available: kettlebell storage insert (MG-AO15T for top tray, MG-AO15B for bottom tray); rubber mat insert (MG-AORM6 for MG-A536 dumbbell rack, MG-AORM8 for MG-A538 dumbbell rack); decal sheet (MG-AODS); connector plate (MG-AOCP)

	PRODUCT DIMENSIONS (L X W X H)						PRODUCT WEIGHT	
	CM		INCHES				KG	LBS
<b>MG-A538</b>	232.2	72.4	101.8	91.5	28.5	40	193	424.6
<b>MG-A536</b>	186.2	72.4	101.8	73.3	28.5	40	160	352



### 10-PAIR STUDIO PRO-STYLE DUMBBELL RACK

Storage space for 10 pairs of pro-style dumbbells from 2-20 kg / 5-50 lbs. • 15-degree angled trays help prevent wrist strain when removing and replacing dumbbells • Space-saving design minimizes footprint and uses less space than traditional 10-pair 2-tier rack • Cradles hold dumbbells securely in place to prevent rolling pinch hazards • Options available: decal sheet (MG-AODS); connector plate (MG-AOCP)

	PRODUCT DIMENSIONS (L X W X H)						PRODUCT WEIGHT	
	CM		INCHES				KG	LBS
<b>MG-A541</b>	186.2	67.3	102.1	73.3	26.5	40.2	123	270.6



### STUDIO FLAT-TRAY DUMBBELL RACK

123 cm / 29" rack holds 2-20 kg / 5-50 lb. hex head dumbbells • Options available: kettlebell storage insert (MG-AO15T for top tray, MG-AO15B for bottom tray); rubber mat insert (MG-AORM4); decal sheet (MG-AODS); connector plate (MG-AOCP)

	PRODUCT DIMENSIONS (L X W X H)						PRODUCT WEIGHT	
	CM		INCHES				KG	LBS
<b>MG-A544</b>	123.2	72.4	101.8	48.5	28.5	39.4	118	259.6



### KETTLEBELL RACK ADAPTERS

Adapters can be added to flat-tray dumbbell racks for kettlebell storage

## AVAILABLE OPTIONS:

### DECAL SHEET

MG-AODS, weight decal sheet allows a facility to label where weights are to be stored; decals range from 2.5-60 (lbs./kg) in increments of 2.5, and 65-150 (lbs./kg) in increments of 5.

<b>2.5</b>	<b>20</b>	<b>37.5</b>	<b>55</b>	<b>85</b>	<b>120</b>
<b>5</b>	<b>22.5</b>	<b>40</b>	<b>57.5</b>	<b>90</b>	<b>125</b>
<b>7.5</b>	<b>25</b>	<b>42.5</b>	<b>60</b>	<b>95</b>	<b>130</b>
<b>10</b>	<b>27.5</b>	<b>45</b>	<b>65</b>	<b>100</b>	<b>135</b>
<b>12.5</b>	<b>30</b>	<b>47.5</b>	<b>70</b>	<b>105</b>	<b>140</b>
<b>15</b>	<b>32.5</b>	<b>50</b>	<b>75</b>	<b>110</b>	<b>145</b>
<b>17.5</b>	<b>35</b>	<b>52.5</b>	<b>80</b>	<b>115</b>	<b>150</b>

MX RACKS /

# STRENGTH WITHOUT LIMITS

No matter how large or small your space, you can design a unique strength training area that maximizes variety and space. A smart design makes it easy to attach over 70 options and components to customize the training challenge to the goals of your members, and you can connect racks in virtually endless ways. You can even make each rack your own with logos, messaging and on-brand colors. And just like everything Magnum, MX Racks will stand up to a steady stream of strength training enthusiasts, day after day for years.





## POWER RACK

Fully enclosed design offers added control during heavy lifts • Durable, 4" x 4", 7-gauge steel uprights with connection points on all four sides let you set up your racks in virtually endless ways • Compatible with over 70 options and components • Also available: MG-MX47-LH low-height and MG-MX47-9 extended versions • MX Racks are shown with attached options

	PRODUCT DIMENSIONS (L X W X H)						PRODUCT WEIGHT	
	CM	INCHES	CM	INCHES	CM	INCHES	KG	LBS
<b>MG-MX47</b>	213.5	127	257	84	50	101	255	562

Visit [matrixfitness.com](http://matrixfitness.com) for the complete listing of available rack options.



## HALF RACK

Open-front design maximizes freedom of movement and training variety • Durable, 4" x 4", 7-gauge steel uprights with connection points on all four sides let you set up your racks in virtually endless ways • Compatible with over 70 options and components • Also available: MG-MX690-LH low-height and MG-MX690-9 extended versions • MX Racks are shown with attached options

	PRODUCT DIMENSIONS (L X W X H)						PRODUCT WEIGHT	
	CM	INCHES	CM	INCHES	CM	INCHES	KG	LBS
<b>MG-MX690</b>	157.5	127	257	62	50	101	185	408



### DOUBLE HALF RACK

Open-front design maximizes freedom of movement and training variety • Back-to-back, space efficient footprint • Durable, 4" x 4", 7-gauge steel uprights with connection points on all four sides let you set up your racks in virtually endless ways • Compatible with over 70 options and components • Also available: MG-MX691-LH low-height and MG-MX691-9 extended versions • MX Racks are shown with attached options

	PRODUCT DIMENSIONS (L X W X H)						PRODUCT WEIGHT	
	CM	INCHES		KG	LBS			
<b>MG-MX691</b>	263	127	257	103.5	50	101	323	712



### COMBO POWER-HALF RACK

Combines the fully enclosed design of the Power Rack with the open design of the Half Rack • Durable, 4" x 4", 7-gauge steel uprights with connection points on all four sides let you set up your racks in virtually endless ways • Compatible with over 70 options and components • Also available: MG-MX47691-LH low-height and MG-MX47691-9 extended versions • MX Racks are shown with attached options

	PRODUCT DIMENSIONS (L X W X H)						PRODUCT WEIGHT	
	CM	INCHES		KG	LBS			
<b>MG-MX47691</b>	312	127	257	123	50	101	396	873



### LAT PULLDOWN

Connects to the rear of an MX47, MX690, PRO47, or PRO690 power rack • Shown with optional MG-S21LR Low Row Kit • No connection kit required.

	PRODUCT DIMENSIONS (L X W X H)						PRODUCT WEIGHT	
	CM		INCHES				KG	LBS
<b>MG-S21XP</b>	165	68.5	247	65	27	97	256.7	566



### ADJUSTABLE PULLEY

Connects to the rear of an MX47, MX690, PRO47, or PRO690 power rack • No connection kit required

	PRODUCT DIMENSIONS (L X W X H)						PRODUCT WEIGHT	
	CM		INCHES				KG	LBS
<b>MG-S23XP</b>	111	27	249	44	10.5	98	188	415

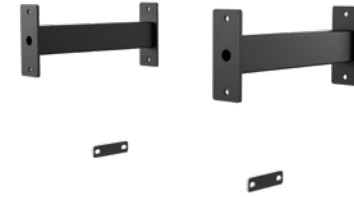

### CONNECTION KIT

Connects two racks back-to-back

	PRODUCT DIMENSIONS (L X W X H)						PRODUCT WEIGHT	
	CM		INCHES				KG	LBS
<b>MXCK</b>	43	15	19	17	6	7.5	7.7	17



### BLANK CROSSBAR

Connects a variety of pull-up bar attachments or custom branded nameplates to racks

	PRODUCT DIMENSIONS (L X W X H)						PRODUCT WEIGHT	
	CM		INCHES				KG	LBS
<b>MXBC</b>	7.5	107	28	3	42	11	9	20

Visit [matrixfitness.com](http://matrixfitness.com) for the complete listing of available rack options.



### BASE CHIN BAR

42" base pull up bar option for use on MX47 or MX47691 racks • Can be used in place of MXBC Blank Crossbar

	PRODUCT DIMENSIONS (L X W X H)						PRODUCT WEIGHT	
	CM		INCHES				KG	LBS
<b>MX06</b>	107	7.75	20.5	42	3	8	5	11



### BOLT-ON WEIGHT HORN

Add additional weight storage horns to the upright • Available in Chrome only

	PRODUCT DIMENSIONS (L X W X H)						PRODUCT WEIGHT	
	CM		INCHES				KG	LBS
<b>XR27C</b>	33	8	8	13	3	3	5	11
<b>XR27C-4</b>	42	14.5	14.5	16.5	5.75	5.75	8.5	19
<b>XR27CS</b>	8	24	8	3.25	9.5	3.25	2	4



### J-HOOKS

Made of high-density polyethylene (HDPE) to protect bar knurling • Fully reversible for use on the inside of any MX Rack, or outside of MX47 and MX47691 racks

	PRODUCT DIMENSIONS (L X W X H)						PRODUCT WEIGHT	
	CM		INCHES				KG	LBS
<b>MX01</b>	29	23	30	11.5	9	12	9	20



### J-HOOK WRAP

Customizes MX01 J-hooks with on-brand colors

	PRODUCT DIMENSIONS (L X W X H)						PRODUCT WEIGHT	
	CM		INCHES				KG	LBS
<b>MX01W</b>	.6	13	15	.25	5	6	.5	1



### DOUBLE J-HOOKS

Made of high-density polyethylene (HDPE) to protect bar knurling • Allows different height users to perform lifts with less adjustment • Fully reversible for use on inside of any MX Rack or outside of MX47 Power Rack and MX47691 Combo Power-Half Racks

	PRODUCT DIMENSIONS (L X W X H)						PRODUCT WEIGHT	
	CM		INCHES				KG	LBS
<b>MX02</b>	22	41	29.5	8.5	16.25	11.5	10	22



### DOUBLE J-HOOK WRAP

Customizes MX02 J-hooks with on-brand colors • Patent Pending

	PRODUCT DIMENSIONS (L X W X H)						PRODUCT WEIGHT	
	CM		INCHES				KG	LBS
<b>MX02W</b>	.6	13	34.5	.25	5	13.5	.7	1.5



### SAFETY ARMS

Adjustable safety arms provide added security during a variety of lifts • Ergonomic hand locations designed for easy adjustments • If attached to the front of the rack, rack must be bolted down or paired with MXO5 Stability Feet w/Band Pegs

	PRODUCT DIMENSIONS (L X W X H)						PRODUCT WEIGHT	
	CM		INCHES				KG	LBS
<b>MXO3</b>	85	33	40	33.5	13	15.75	28	62



### HALF RACK SAFETY ARM WRAP

Customizes MXO3 Half Rack Safety Arms with on-brand colors

	PRODUCT DIMENSIONS (L X W X H)						PRODUCT WEIGHT	
	CM		INCHES				KG	LBS
<b>MXO3W</b>	11	69	4	4.5	27	1.5	2	4



### SAFETY ARM STRAPS

Provides a more secure lifting experience • Protects equipment from damage • Reduces noise from dropped weights • 4" extra wide straps for maximum support

	PRODUCT DIMENSIONS (L X W X H)						PRODUCT WEIGHT	
	CM		INCHES				KG	LBS
<b>MXO4</b>	135	28	19	53	11	7.5	15.5	34



### STABILITY FEET

Provides added stability during heavy lifts performed at the front of a power rack • For use with MG-MX47

	PRODUCT DIMENSIONS (L X W X H)						PRODUCT WEIGHT	
	CM		INCHES				KG	LBS
<b>MXO5</b>	85	41	31	33.5	16.25	12.25	17	37.5



### ANGLED PULL-UP BAR

Provides additional bodyweight training • Connects to MXBC, MXO50, MXO51, MXO52

	PRODUCT DIMENSIONS (L X W X H)						PRODUCT WEIGHT	
	CM		INCHES				KG	LBS
<b>MXO7</b>	20	100	7	8	39.5	2.75	6.5	14.5



### ANGLED FAT PULL-UP BAR

Provides additional bodyweight training • Connects to MXBC, MXO50, MXO51, MXO52

	PRODUCT DIMENSIONS (L X W X H)						PRODUCT WEIGHT	
	CM		INCHES				KG	LBS
<b>MXO7F</b>	22	102	7.5	8.5	40	3	8.5	19

Visit [matrixfitness.com](http://matrixfitness.com) for the complete listing of available rack options.



### SPHERE BALL GRIPS

Improves grip strength during pull ups and other bodyweight exercises • Connects to MXBC, MXO50, MXO51, MXO52

	PRODUCT DIMENSIONS (L X W X H)						PRODUCT WEIGHT	
	CM			INCHES			KG	LBS
	<b>MX08</b>	16.5	103	7.5	6.5	40.5	3	7.5



### ROCK CLIMBING GRIPS

Improves grip strength during pull-ups and other bodyweight exercises • Connects to MXBC, MXO50, MXO51, MXO52

	PRODUCT DIMENSIONS (L X W X H)						PRODUCT WEIGHT	
	CM			INCHES			KG	LBS
	<b>MX09</b>	30	8	5	12	3.25	2	.5



### UPPER OLYMPIC BAR STORAGE

Provides easily accessible storage for an additional Olympic bar

	PRODUCT DIMENSIONS (L X W X H)						PRODUCT WEIGHT	
	CM			INCHES			KG	LBS
	<b>MX015</b>	7.75	12	20.5	3	5	8	1.5



### UPPER DUAL OLYMPIC BAR STORAGE

Provides easily accessible storage for up to 2 additional Olympic bars

	PRODUCT DIMENSIONS (L X W X H)						PRODUCT WEIGHT	
	CM			INCHES			KG	LBS
	<b>MX016</b>	16.5	12	20.5	6.5	5	8	2

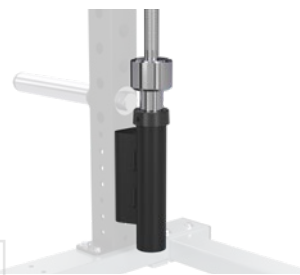

### LOWER OLYMPIC BAR STORAGE

Provides easily accessible storage for an additional Olympic bar • Available in Matte Black only

	PRODUCT DIMENSIONS (L X W X H)						PRODUCT WEIGHT	
	CM			INCHES			KG	LBS
	<b>MX017</b>	13	8.5	32	5	3.5	12.5	3.5



### LOWER DUAL OLYMPIC BAR STORAGE

Provides easily accessible storage for up to 2 additional Olympic bars • Available in Matte Black only

	PRODUCT DIMENSIONS (L X W X H)						PRODUCT WEIGHT	
	CM			INCHES			KG	LBS
	<b>MX018</b>	13	17	32	5	6.75	12.5	5.5



### LOWER OLYMPIC BAR STORAGE ADD-ON

Provides easily accessible storage for up to 2 additional Olympic bars • Combine with the MXO17 or MXO18 to create a 3 or 4 Olympic bar storage option • Available in Matte Black only.

	PRODUCT DIMENSIONS (L X W X H)						PRODUCT WEIGHT	
	CM		INCHES				KG	LBS
<b>MXO19</b>	13	33	32	5	13	12.5	5.5	12



### OLYMPIC BAR HOLDER

Bolt-on Olympic bar holder • Available in Matte Black only

	PRODUCT DIMENSIONS (L X W X H)						PRODUCT WEIGHT	
	CM		INCHES				KG	LBS
<b>XR34</b>	28	20.5	8	11	8	3	2.6	5



### DUAL-OLYMPIC BAR HOLDER

Bolt-on Olympic bar holder • Available in Matte Black only

	PRODUCT DIMENSIONS (L X W X H)						PRODUCT WEIGHT	
	CM		INCHES				KG	LBS
<b>XR23</b>	13	28	23	5	11	9	4.5	10

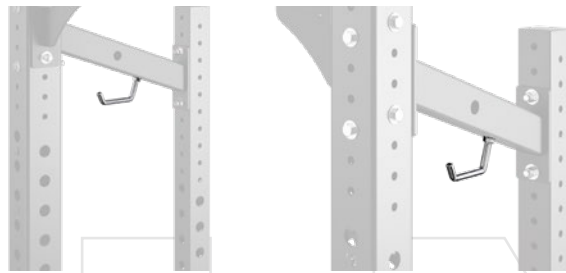

### BAND STORAGE

Provides convenient on-rack resistance band storage

	PRODUCT DIMENSIONS (L X W X H)						PRODUCT WEIGHT	
	CM		INCHES				KG	LBS
<b>MXO20</b>	11	2.5	12	4.5	1	5	.5	1



### WEIGHT ACCESSORY STORAGE

Stores various weight plates and accessories

	PRODUCT DIMENSIONS (L X W X H)						PRODUCT WEIGHT	
	CM		INCHES				KG	LBS
<b>MXO22</b>	86.5	61.6	59.7	34	24.25	23.5	37.2	82

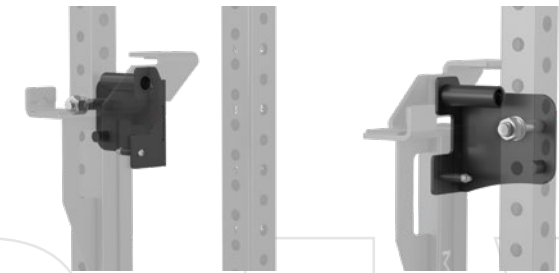

### SAFETY ARM STORAGE

Bolt-on safety arm storage for half rack style safety arms (MG-MXO3)

	PRODUCT DIMENSIONS (L X W X H)						PRODUCT WEIGHT	
	CM		INCHES				KG	LBS
<b>MXO23</b>	22	20.5	23	8.6	8.1	9	8.25	18.25

Visit [matrixfitness.com](http://matrixfitness.com) for the complete listing of available rack options.



### DIP BAR STORAGE

Bolt-on hooks to store MXO33 Dip Bars • Made of high-density polyethylene (HDPE) to protect Dip Bars from damage when not in use

	PRODUCT DIMENSIONS (L X W X H)						PRODUCT WEIGHT	
	CM		INCHES				KG	LBS
<b>MXO24</b>	23.5	16.4	15.8	9.25	6.5	6.25	3.6	8



### LEG ROLLER STORAGE

Bolt-on storage for the MG-MXO34 Leg Roller

	PRODUCT DIMENSIONS (L X W X H)						PRODUCT WEIGHT	
	CM		INCHES				KG	LBS
<b>MXO25</b>	19.6	4.2	19	7.75	1.75	7.5	2.3	5



### DIP BAR

Used for bodyweight dips • Must be used off front of rack unless rack is bolted down

	PRODUCT DIMENSIONS (L X W X H)						PRODUCT WEIGHT	
	CM		INCHES				KG	LBS
<b>MXO33</b>	73	73	20	28.75	28.75	8	10	22



### PREMIUM LANDMINE ATTACHMENT

Pad allows users to perform multiple single leg movements • Use with a bench to perform Glute/Ham exercises • Used for rotational training

	PRODUCT DIMENSIONS (L X W X H)						PRODUCT WEIGHT	
	CM		INCHES				KG	LBS
<b>MOPT13</b>	67	21	19.5	26.3	8.3	7.7	9.5	21



### BOLT-ON LANDMINE

Used for rotational training • Available in Matte Black only

	PRODUCT DIMENSIONS (L X W X H)						PRODUCT WEIGHT	
	CM		INCHES				KG	LBS
<b>XR18</b>	41	10.5	20.5	16	4	8	3.7	8



### CORE HANDLE

Used with an Olympic bar and Land Mine Attachment for added training variety • Available in Ridge Black only

	PRODUCT DIMENSIONS (L X W X H)						PRODUCT WEIGHT	
	CM		INCHES				KG	LBS
<b>OPT16</b>	48	79	5	19	31	2	5	10



### PREMIUM BATTLE ROPE ATTACHMENT

For rope training as an anchor point • Smooth chrome finish for rope protection

	PRODUCT DIMENSIONS (L X W X H)						PRODUCT WEIGHT	
	CM			INCHES			KG	LBS
<b>MOPT31</b>	18	23	17	7	9	7	4	7



### ROPE ANCHOR

For rope training as an anchor point  
• Available in Matte Black only

	PRODUCT DIMENSIONS (L X W X H)						PRODUCT WEIGHT	
	CM			INCHES			KG	LBS
<b>XR16</b>	15.5	8	23	6	3	9	1.4	3

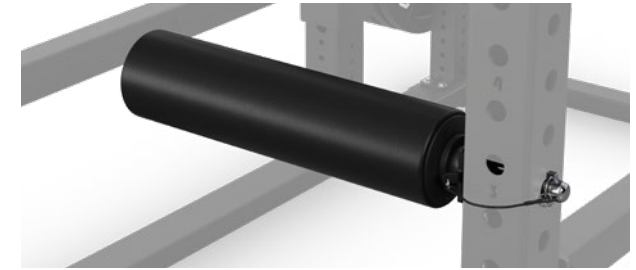

### LEG ROLLER

Pad allows users to perform multiple single leg movements • Use with a bench to perform Glute/Ham exercises

	PRODUCT DIMENSIONS (L X W X H)						PRODUCT WEIGHT	
	CM			INCHES			KG	LBS
<b>MXO34</b>	75.5	14	14	29.75	5.5	5.5	11	24.25



### NORDIC CURL MOUNT

Combine with the MG-MXO34 Leg Roller to perform Nordic Curls

	PRODUCT DIMENSIONS (L X W X H)						PRODUCT WEIGHT	
	CM			INCHES			KG	LBS
<b>MXO34NM</b>	11.7	10	23	4.6	4	9	3	6.5



### BAND PEGS

Provides an attachment point for resistance bands for added training variety

	PRODUCT DIMENSIONS (L X W X H)						PRODUCT WEIGHT	
	CM			INCHES			KG	LBS
<b>MXO35</b>	48.5	5	10	19	2	4	2.6	5.75

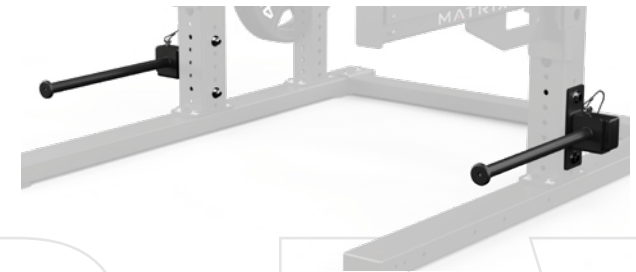

### ADJUSTABLE BAND PEGS

Adjustable band pegs provide added training variety • Must be used in conjunction with the MXO12 Band Peg Mount

	PRODUCT DIMENSIONS (L X W X H)						PRODUCT WEIGHT	
	CM			INCHES			KG	LBS
<b>MXO11</b>	56.77	7.6	11.2	22.35	3	4.41	3.1	6.7

Visit [matrixfitness.com](http://matrixfitness.com) for the complete listing of available rack options.



### ADJUSTABLE BAND PEG MOUNTS

Mounts to MX racks for use with the MXO11 Adjustable Band Pegs

	PRODUCT DIMENSIONS (L X W X H)						PRODUCT WEIGHT	
	CM			INCHES			KG	LBS
	CM	INCHES	CM	INCHES	CM	INCHES	KG	LBS
<b>MXO12</b>	11.56	7.62	20.32	4.55	3	8	1.9	4.3

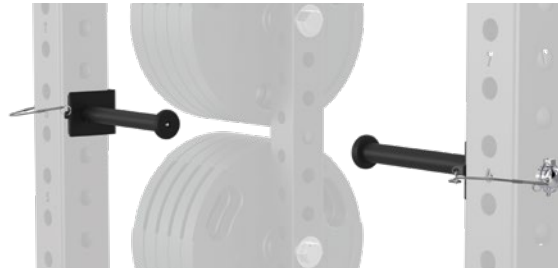

### SQUAT HANDLES

Easily adjustable handles to assist in performing various squat and band exercises.

	PRODUCT DIMENSIONS* (L X W X H)						PRODUCT WEIGHT	
	CM			INCHES			KG	LBS
	CM	INCHES	CM	INCHES	CM	INCHES	KG	LBS
<b>MXO37</b>	40	8.5	11.5	15.75	3.25	4.5	2.3	5

\*Specs listed are per handle



### BOLT-ON FRONT BAND PEGS

Two bolt-on upper band pegs for added training variety • Available in Ridge Black only

	PRODUCT DIMENSIONS (L X W X H)						PRODUCT WEIGHT	
	CM			INCHES			KG	LBS
	CM	INCHES	CM	INCHES	CM	INCHES	KG	LBS
<b>OPT46</b>	28	16	27	11	6.25	10.5	4	9



### UNIVERSAL BAND ATTACHMENT

Upper attachment point for bands or suspension straps • Rack must be bolted down to use this option • Available in Matte Black only

	PRODUCT DIMENSIONS (L X W X H)						PRODUCT WEIGHT	
	CM			INCHES			KG	LBS
	CM	INCHES	CM	INCHES	CM	INCHES	KG	LBS
<b>XR35</b>	15.5	2.5	20.5	6	1	8	1	2



### STABILITY BALL HOLDER - UPRIGHT

Connects to weight storage upright to store 1 stability ball

	PRODUCT DIMENSIONS (L X W X H)						PRODUCT WEIGHT	
	CM			INCHES			KG	LBS
	CM	INCHES	CM	INCHES	CM	INCHES	KG	LBS
<b>MXO38</b>	37	41	26.5	14.5	16	10.5	2.5	6



### STABILITY BALL HOLDER - TOP

Connects to top of rack to store 1 stability ball

	PRODUCT DIMENSIONS (L X W X H)						PRODUCT WEIGHT	
	CM			INCHES			KG	LBS
	CM	INCHES	CM	INCHES	CM	INCHES	KG	LBS
<b>MXO39</b>	37	48.5	.6	14.5	19	.25	2	4.5



### JAMMIN ARMS

Pressing arms can be placed at various heights for added training variety • Multiple grips for added exercise variety

	PRODUCT DIMENSIONS (L X W X H)						PRODUCT WEIGHT	
	CM		INCHES				KG	LBS
<b>MXD42</b>	44.5	76	129.5	17.5	30	51	59.6	131.5



### HEAVY BAG ATTACHMENT

Boom arm to hold heavy bags or suspension straps • Can be used on the PRO690C 8' half rack only • Rack must be bolted down to use this option • Available in Matte Black only

	PRODUCT DIMENSIONS (L X W X H)						PRODUCT WEIGHT	
	CM		INCHES				KG	LBS
<b>XR14</b>	107	8	48.5	42	3	19	9.1	20



### BALL TARGET

Used for overhead ball work • Can be used on the PRO690C 8' half rack only • Available in Matte Black only

	PRODUCT DIMENSIONS (L X W X H)						PRODUCT WEIGHT	
	CM		INCHES				KG	LBS
<b>XR22</b>	41	130	6	16	51	2.25	10.9	24

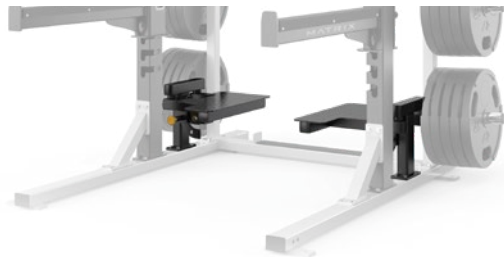

### BOLT-ON SPOTTER STANDS

Step-up platform used for assisting in heavy lifts

	PRODUCT DIMENSIONS (L X W X H)						PRODUCT WEIGHT	
	CM		INCHES				KG	LBS
<b>OPT45</b>	38	81.5	29.5	15	32	11.5	31	68



### SHELF MOUNTING BRACKET

Used to connect an end of a shelf to an upright • Available in Matte Black only

	PRODUCT DIMENSIONS (L X W X H)						PRODUCT WEIGHT	
	CM		INCHES				KG	LBS
<b>XS18</b>	20.5	8	8	8	3	3	1.9	4



### 70" MEDICINE BALL SHELF

Medicine Ball storage shelf that attaches between 2 racks • Requires XS11 or XS18 mounting brackets to connect to a rack • Available in Matte Black only

	PRODUCT DIMENSIONS (L X W X H)						PRODUCT WEIGHT	
	CM		INCHES				KG	LBS
<b>XS02</b>	30.5	178	8	12	70	3	12.3	27

Visit [matrixfitness.com](http://matrixfitness.com) for the complete listing of available rack options.



### 70" DB / KB SHELF

Dumbbell/Kettlebell storage shelf that attaches between 2 racks • Requires XS11 or XS18 mounting brackets to connect to a rack • Available in Matte Black only

	PRODUCT DIMENSIONS (L X W X H)						PRODUCT WEIGHT	
	CM			INCHES			KG	LBS
<b>XS06</b>	38.5	178	8	15	70	3	23.6	52



### 70" BUMPER / BOSU RACK

Storage rack designed to store Bumper plates or Bosu's that attaches between 2 racks • No mounting brackets required • Available in Matte Black only

	PRODUCT DIMENSIONS (L X W X H)						PRODUCT WEIGHT	
	CM			INCHES			KG	LBS
<b>XS08</b>	30.5	178	43.5	12	70	17	16.4	36

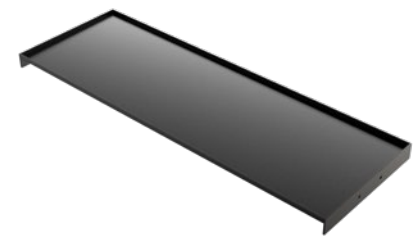

### 70" STORAGE SHELF

Extra deep shelf used for storing various accessories • Attaches between 2 racks • Requires XS11 or XS18 mounting brackets to connect to a rack • Available in Matte Black only

	PRODUCT DIMENSIONS (L X W X H)						PRODUCT WEIGHT	
	CM			INCHES			KG	LBS
<b>XS10</b>	61	178	8	24	70	3	31.8	70



### 70" SINGLE CHIN BAR

70" straight chin bar for connecting racks side-to-side or back-to-back • Can be used on the PRO690C 8' half rack only • Available in Matte Black only

	PRODUCT DIMENSIONS (L X W X H)						PRODUCT WEIGHT	
	CM			INCHES			KG	LBS
<b>XR02</b>	86	69	26	34	27	10	16	35



### 70" CONNECTING BAR

Connects racks side-to-side • Allows for multiple pull-up bar options

	PRODUCT DIMENSIONS (L X W X H)						PRODUCT WEIGHT	
	CM			INCHES			KG	LBS
<b>MX050</b>	178	7.5	20	70	3	8	12.5	28

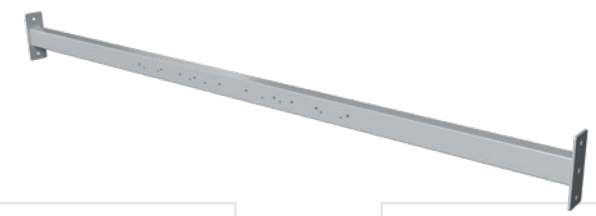

### 96" CONNECTING BAR

Connects racks side-to-side • Allows for multiple pull-up bar options

	PRODUCT DIMENSIONS (L X W X H)						PRODUCT WEIGHT	
	CM			INCHES			KG	LBS
<b>MX051</b>	244	7.5	20	96	3	8	16.5	37



### 70" STRAIGHT LADDER

Horizontal ladder connects power racks together for additional bodyweight training and added versatility

	PRODUCT DIMENSIONS (L X W X H)						PRODUCT WEIGHT	
	CM		INCHES				KG	LBS
<b>MX052</b>	178	122	30	70	48	11.75	41	91



### 96" STRAIGHT LADDER

Horizontal ladder connects power racks together for additional bodyweight training and added versatility

	PRODUCT DIMENSIONS (L X W X H)						PRODUCT WEIGHT	
	CM		INCHES				KG	LBS
<b>MX053</b>	244	122	30	96	48	11.75	57	126



### 96" PYRAMID LADDER

Elevated ladder connects power racks together for additional bodyweight training and added versatility

	PRODUCT DIMENSIONS (L X W X H)						PRODUCT WEIGHT	
	CM		INCHES				KG	LBS
<b>MX054</b>	244	122	56	96	48	22	54	119



### PYRAMID LADDER LASER CUT NAMEPLATE

Proudly display your logo above your rack • Adds a custom laser cut nameplate to a MX054 Pyramid Ladder • Provides custom messaging and branding • Laser cut nameplate design offers long lasting durability

	PRODUCT DIMENSIONS (L X W X H)						PRODUCT WEIGHT	
	CM		INCHES				KG	LBS
<b>MX054L</b>	67.5	.75	28	26.5	.25	11	11.5	26



### ARCH NAMEPLATE DECAL

Proudly display your logo above your rack • Provides custom messaging and branding • Adds a custom nameplate with vinyl decals to any rack

	PRODUCT DIMENSIONS (L X W X H)						PRODUCT WEIGHT	
	CM		INCHES				KG	LBS
<b>MX060</b>	2.5	104	20	1	41	8	2	4.5



### ARCH NAMEPLATE LASER CUT

Proudly display your logo above your rack • Adds a custom laser cut arched nameplate to any rack • Provides custom messaging and branding • Laser cut design offers long lasting durability

	PRODUCT DIMENSIONS (L X W X H)						PRODUCT WEIGHT	
	CM		INCHES				KG	LBS
<b>MX061</b>	2.5	104	20	1	41	8	3.5	8

Visit [matrixfitness.com](http://matrixfitness.com) for the complete listing of available rack options.



### ARCH NAMEPLATE DOUBLE-SIDED LASER CUT

Proudly display your logo above your rack • Adds a custom double-sided laser cut arched nameplate to any rack • Double-Sided for maximum brand visibility • Provides custom messaging and branding • Laser cut design offers long lasting durability

	PRODUCT DIMENSIONS (L X W X H)						PRODUCT WEIGHT	
	CM		INCHES				KG	LBS
<b>MX061D</b>	2.5	104	20	1	41	8	6.5	14



### ARCH NAMEPLATE LASER CUT W/DECAL

Proudly display your school or facility name / logo on a custom metal nameplate for inside your power rack

	PRODUCT DIMENSIONS (L X W X H)						PRODUCT WEIGHT	
	CM		INCHES				KG	LBS
<b>MX061V</b>	2.5	104	20	1	41	8	11.1	24.5



### ARCH NAMEPLATE LASER CUT W/DECAL

Proudly display your school or facility name / logo on a double-sided custom metal nameplate for inside your power rack

	PRODUCT DIMENSIONS (L X W X H)						PRODUCT WEIGHT	
	CM		INCHES				KG	LBS
<b>MX061DV</b>	2.5	104	20	1	41	8	11.4	25



### UPPER NAMEPLATE DECAL

Proudly display your logo above your rack • Adds a custom nameplate with vinyl decal to the top of any rack • Provides custom messaging and branding

	PRODUCT DIMENSIONS (L X W X H)						PRODUCT WEIGHT	
	CM		INCHES				KG	LBS
<b>MX062</b>	4	104	16	1.75	41	6.5	2.5	5.5



### UPPER NAMEPLATE LASER CUT

Proudly display your logo above your rack • Adds a custom laser cut nameplate to the top of a rack • Provides custom messaging and branding • Laser cut design offers long lasting durability

	PRODUCT DIMENSIONS (L X W X H)						PRODUCT WEIGHT	
	CM		INCHES				KG	LBS
<b>MX063</b>	4	104	16	1.75	41	6.5	3.5	7.5



### 70" NAME PLATE

Display your logo proudly between 2 racks • Can be used on the PRO690C 8' half rack only • Available in Matte Black only

	PRODUCT DIMENSIONS (L X W X H)						PRODUCT WEIGHT	
	CM		INCHES				KG	LBS
<b>XR26</b>	30.5	190.5	5	12	75	2	8.7	19



### 70" NAMEPLATE W/PULL-UP BAR DECAL

Proudly display your logo above your rack • Adds a custom nameplate with vinyl decal to a rack • Includes a pull-up bar and attachment points for various accessories

	PRODUCT DIMENSIONS (L X W X H)					PRODUCT WEIGHT		
	CM		INCHES			KG	LBS	
<b>MX064</b>	178	28	31	70	11	12.25	30	67



### 70" NAMEPLATE W/PULL-UP BAR DOUBLE SIDED DECAL

Proudly display your logo above your rack • Adds a custom double-sided nameplate with vinyl decals to a rack • Double-Sided for maximum brand visibility • Includes a pull-up bar and attachment points for various accessories

	PRODUCT DIMENSIONS (L X W X H)					PRODUCT WEIGHT		
	CM		INCHES			KG	LBS	
<b>MX064D</b>	178	28	31	70	11	12.25	36	80



### 70" NAMEPLATE W/PULL-UP BAR LASER CUT

Proudly display your logo above your rack • Adds a custom laser cut nameplate to a rack • Includes a pull-up bar and attachment points for various accessories • Laser cut design offers long lasting durability

	PRODUCT DIMENSIONS (L X W X H)					PRODUCT WEIGHT		
	CM		INCHES			KG	LBS	
<b>MX065</b>	178	28	31	70	11	12.25	34.5	76



### 70" NAMEPLATE W/PULL-UP BAR DOUBLE SIDED LASER CUT

Proudly display your logo above your rack • Adds a custom double-sided laser cut nameplate to a rack • Double-Sided for maximum brand visibility • Includes a pull-up bar and attachment points for various accessories • Laser cut design offers long lasting durability

	PRODUCT DIMENSIONS (L X W X H)					PRODUCT WEIGHT		
	CM		INCHES			KG	LBS	
<b>MX065D</b>	178	28	31	70	11	12.25	45	100



### 70" NAMEPLATE W/PULL-UP BAR LASER CUT W/DECAL

Proudly display your school or facility name/logo on a custom metal nameplate • Includes a pull-up bar and attachment points for various accessories

	PRODUCT DIMENSIONS (L X W X H)					PRODUCT WEIGHT		
	CM		INCHES			KG	LBS	
<b>MX065V</b>	178	28	31	70	11	12.25	41.5	91.5



### 70" NAMEPLATE W/PULL-UP BAR DOUBLE SIDED LASER CUT W/DECAL

Proudly display your school or facility name/logo on a double-sided custom metal nameplate • Includes a pull-up bar and attachment points for various accessories

	PRODUCT DIMENSIONS (L X W X H)					PRODUCT WEIGHT		
	CM		INCHES			KG	LBS	
<b>MX065DV</b>	178	28	31	70	11	12.25	58.3	128.5

Visit [matrixfitness.com](http://matrixfitness.com) for the complete listing of available rack options.



### PLATFORM RAMP

Ramp allows for gradual incline to rack platforms  
 • Available in Ridge Black only

	PRODUCT DIMENSIONS (L X W X H)						PRODUCT WEIGHT	
	CM		INCHES				KG	LBS
OPT11	14.5	107	6.5	5.7	42	2.5	6	13.2



### CUSTOM PLATFORM LOGO

Proudly display your facility logo on the platform (OPT10)



# MAGNUM VRS PLATFORM

Reduce sound by 21% and bounce by 67% while protecting your equipment with our Vibration Reduction System.

Create an unmatched strength training environment with platforms featuring our exclusive Vibration Reduction System. Our impact-absorption platforms reduce sound and bounce caused by dropping barbells during Olympic lifts, protecting floors, bars, weights, and plates from hard use. The multi-layer design minimizes vibrations transferred through floors, essential for above-ground training facilities. VRS Platform kits are available in a variety of styles and sizes, so it's easy to upgrade existing Matrix platforms or create a rugged new training experience featuring our Vibration Reduction System.

	PRODUCT DIMENSIONS (L X W X H)						PRODUCT WEIGHT	
	CM	INCHES		KG	LBS			
PS86-VRS	191	254	7	75	100	2.6	184	406
PS84-VRS	131	254	7	51.5	100	2.6	131	289
MG-PRO47P-VRS	340	254	7	134	100	2.6	227	500.5
MG-PRO47P-VRS-4	280	254	7	110	100	2.6	174	383.5
MG-PRO9091P-VRS	303	254	7	119	100	2.6	218	480.5
MG-PRO9091P-VRS-4	243	254	7	96	100	2.6	165	363.5
VRS-KIT	181.5	68	11.5	71.5	26.8	4.5	71	156
VRS-KIT-4	121	68	11.5	48	26.8	4.5	47.5	104
MG-MX47P-VRS-06	390	254	7	153.5	100	2.6	231	509
MG-MX47P-VRS-4-06	329	254	7	129.5	100	2.6	186.5	411
MG-MX47P-CPH-VRS-06	366.5	254	7	144.5	100	2.6	222.5	491
MG-MX47P-CPH-VRS-4-06	306	254	7	120.5	100	2.6	178	393
MG-MX690P-VRS-06	333.5	254	7	131.5	100	2.6	210	463
MG-MX690P-VRS-4-06	273	254	7	107.5	100	2.6	166	366
MG-MX691P-VRS-06	318.5	254	7	125.5	100	2.6	205	452
MG-MX691P-VRS-4-06	258	254	7	101.5	100	2.6	160	353

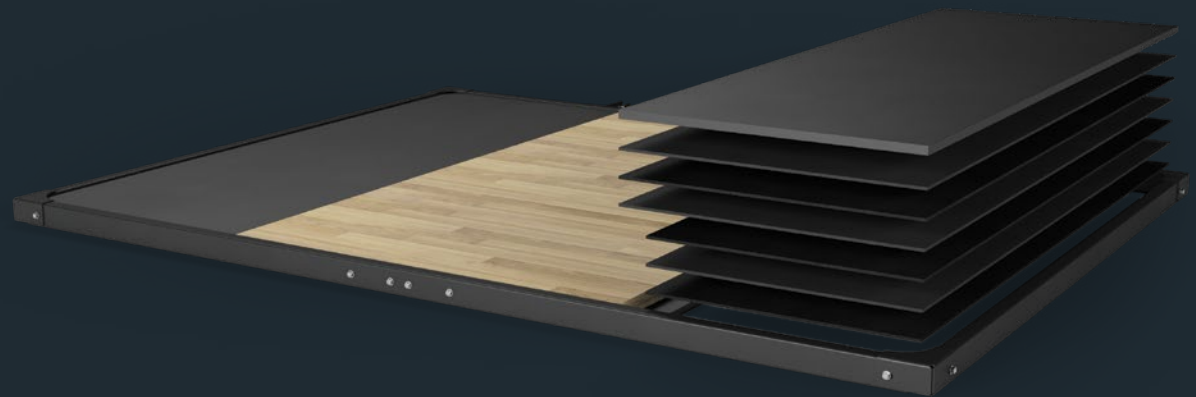



### MX PLATFORM W/ BAMBOO INSERT

Durable rubber training surface to absorb impact, dampen noise and protect flooring during Olympic lifts • Bamboo center insert provides optimum foot grip and stability during explosive Olympic lifts • Available training area length options: 122 cm / 48" (-4 version) or 182 cm / 72"

	PRODUCT DIMENSIONS (L X W X H)						PRODUCT WEIGHT	
	CM			INCHES			KG	LBS
<b>MX47P</b>	390	254	7	153.5	100	2.6	287	633
<b>MX47P-4</b>	329	254	7	129.5	100	2.6	224	494
<b>MX47P-CPH</b>	366.5	254	7	144.5	100	2.6	278	613
<b>MX47P-CPH-4</b>	306	254	7	120.5	100	2.6	215	474
<b>MX690P</b>	333.5	254	7	131.5	100	2.6	266	587
<b>MX690P-4</b>	273	254	7	107.5	100	2.6	203	448
<b>MX691P</b>	318.5	254	7	125.5	100	2.6	260.5	575
<b>MX691P-4</b>	258	254	7	101.5	100	2.6	197	435



### MX SOLID RUBBER SURFACE PLATFORM

Durable rubber training surface to absorb impact, dampen noise and protect flooring during Olympic lifts • Available training area length options: 122 cm / 48" (-4 version) or 182 cm / 72"

	PRODUCT DIMENSIONS (L X W X H)						PRODUCT WEIGHT	
	CM			INCHES			KG	LBS
<b>MXRP47</b>	390	254	7	153.5	100	2.6	324.5	716
<b>MXRP47-4</b>	329	254	7	129.5	100	2.6	247.5	546
<b>MXRP47-CPH</b>	366.5	254	7	144.5	100	2.6	314	693
<b>MXRP47-CPH-4</b>	306	254	7	120.5	100	2.6	237	523
<b>MXRP690</b>	333.5	254	7	131.5	100	2.6	298.5	658
<b>MXRP690-4</b>	273	254	7	107.5	100	2.6	222	490
<b>MXRP691</b>	318.5	254	7	125.5	100	2.6	291.5	643
<b>MXRP691-4</b>	258	254	7	101.5	100	2.6	215	474



### STAND-ALONE PLATFORM W/BAMBOO INSERT

Durable rubber training surface to absorb impact, dampen noise and protect flooring during explosive Olympic lifts • Bamboo center insert provides optimum foot grip and stability during explosive Olympic lifts • Available training area length options: 122 cm / 48" (-4 version) or 182 cm / 72"

	PRODUCT DIMENSIONS (L X W X H)						PRODUCT WEIGHT	
	CM			INCHES			KG	LBS
<b>PS84</b>	131	254	7	51.5	100	2.6	153	337
<b>PS86</b>	191	254	7	75	100	2.6	216.5	477



### STAND-ALONE SOLID RUBBER PLATFORM

Durable rubber training surface to absorb impact, dampen noise and protect flooring during Olympic lifts • Available training area length options: 122 cm / 48" (RP84) or 182 cm / 72" (RP86)

	PRODUCT DIMENSIONS (L X W X H)						PRODUCT WEIGHT	
	CM			INCHES			KG	LBS
<b>RP84</b>	131	254	7	51.5	100	2.6	156	344
<b>RP86</b>	191	254	7	75	100	2.6	233	514



MAGNUM PRO RACKS /

# CUSTOM-MADE FOR STRENGTH

Now you can customize your strength training offering and make the most of your floor space with ultra-durable Magnum Pro Series Configurable Racks. Our versatile design lets you attach options and accessories to all four sides of the uprights and expand your racks in any direction. Optional storage makes room for Olympic bars, bumper plates, dumbbells, kettlebells, med balls and more, keeping your floor clutter-free. Choose 7' or 8' uprights to fit your space, and bring Magnum Pro Series Configurable Racks to your facility today.





### PRO POWER RACK

Includes adjustable safety arms, j-hooks, 4 straight chin bars, and 4-post chromed bumper plate storage • Fully enclosed design offers ideal spotting abilities • J-hooks made of high density polyethylene (HDPE) to protect bar knurling from scratches • Also available: MG-PRO47-7' Power Rack • Combine with an MG-PRO47C rack to create a combo rack that can use storage shelves and have standard weight horns on the outside.

	PRODUCT DIMENSIONS (L X W X H)						PRODUCT WEIGHT	
	CM		INCHES				KG	LBS
<b>MG-PRO47</b>	178	183	243	70	72	95.5	156.5	345



### PRO CONFIGURABLE POWER RACK

Includes adjustable safety arms, j-hooks, and a 4 straight chin bars • J-hooks made of high density polyethylene (HDPE) to protect bar knurling from scratches • Optional chromed weight horns and/or storage shelves can be added to create a variety of storage solutions • Fully enclosed design offers ideal spotting abilities • Also available: MG-PRO47C-7' 7' Configurable Power Rack • Combine with an MG-PRO47 rack to create a combo rack that can use storage shelves and have standard weight horns on the outside.

	PRODUCT DIMENSIONS (L X W X H)						PRODUCT WEIGHT	
	CM		INCHES				KG	LBS
<b>MG-PRO47C</b>	178	132	243	70	52	95.5	165	363



## PRO XL HALF RACK

Includes adjustable safety arms, j-hooks, angled pull-up bar, and 10 weight storage horns (5 per side) • Open-front design gives users freedom of movement • Robust 3"x4" 7-gauge steel uprights.

	PRODUCT DIMENSIONS (L X W X H)					PRODUCT WEIGHT		
	CM		INCHES		KG	LBS		
<b>MG-PRO690EX</b>	142.5	187	255.5	56	73.5	100.5	172	379

Visit [matrixfitness.com](http://matrixfitness.com) for the complete listing of available rack options.



### PRO HALF RACK

Includes adjustable safety arms, j-hooks, straight chin bar, and 4-post chromed bumper plate storage • Open-front design gives users freedom of movement • J-hooks made of high density polyethylene (HDPE) to protect bar knurling from scratches • Also available: MG-PRO690-7 7' Half Rack • Combine with an MG-PRO690C rack to create a combo rack that can use storage shelves and have standard weight horns on the outside

	PRODUCT DIMENSIONS (L X W X H)						PRODUCT WEIGHT	
	CM			INCHES			KG	LBS
<b>MG-PRO690</b>	141	183	243	55.5	72	95.5	111	244.5



### PRO CONFIGURABLE HALF RACK

Includes adjustable safety arms, j-hooks, and a straight chin bar • J-hooks made of high density polyethylene (HDPE) to protect bar knurling from scratches • Optional chromed weight horns and/or storage shelves can be added to create a variety of storage solutions • Open-front design gives users freedom of movement • Also available: MG-PRO690C-7 7' Configurable Half Rack • Combine with an MG-PRO690 rack to create a combo rack that can use storage shelves and have standard weight horns on the outside

	PRODUCT DIMENSIONS (L X W X H)						PRODUCT WEIGHT	
	CM			INCHES			KG	LBS
<b>MG-PRO690C</b>	141	132	243	55.5	52	95.5	116.5	257



### PRO DOUBLE HALF RACK

Designed for training efficiency • Includes adjustable safety arms, j-hooks, straight chin bars, and 4-post Bumper plate storage • Also available: MG-PRO691-7 7' Double Half Rack • J-hooks made of high density polyethylene (HDPE) to protect bar knurling from scratches • Combine with an MG-PRO691C rack to create a combo rack that can use storage shelves and have standard weight horns on the outside

	PRODUCT DIMENSIONS (L X W X H)						PRODUCT WEIGHT	
	CM	INCHES		CM	INCHES		KG	LBS
<b>MG-PRO691</b>	229	183	243	90	72	95.5	180	397



### PRO CONFIGURABLE DOUBLE HALF RACK

Designed for training efficiency • Includes adjustable safety arms, j-hooks, and straight chin bars • Also available: MG-PRO691C-7 7' Configurable Double Half Rack • J-hooks made of high density polyethylene (HDPE) to protect bar knurling from scratches • Optional chromed weight horns and/or storage shelves can be added to create a variety of storage solutions • Combine with an MG-PRO691 rack to create a combo rack that can use storage shelves and have standard weight horns on the outside.

	PRODUCT DIMENSIONS (L X W X H)						PRODUCT WEIGHT	
	CM	INCHES		CM	INCHES		KG	LBS
<b>MG-PRO691C</b>	229	132	243	90	52	95.5	190	419

Visit [matrixfitness.com](http://matrixfitness.com) for the complete listing of available rack options.



# MAGNUM PRO RACKS

For the complete collection of compatible options and platforms for PRO Racks, visit our website.

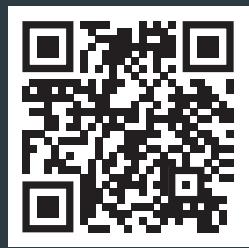

## MAGNUM STANDARD FRAME COLORS



Iced Silver†



Black Glossy



Matte Black†

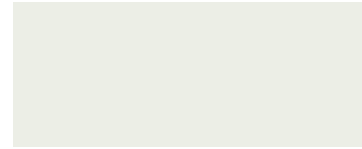

Lace White



Polarized Titanium

## MAGNUM FRAME COLOR OPTIONS



Blue Streak



Hi-lite Yellow



Sunburst Orange



Blood Red

## MAGNUM UPHOLSTERY COLOR OPTIONS

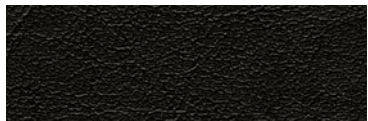

Black



Slate Blue

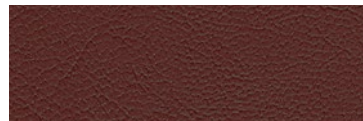

Clay Red

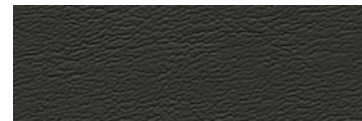

Graphite

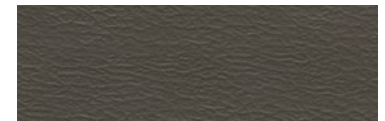

Alloy

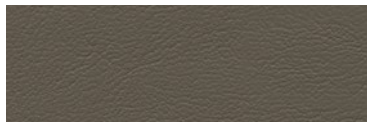

Hazelnut



American Beauty



Candy Apple



New Burgundy



Paprika



Nasturtium



Mandarin Orange



Sun Yellow



Marigold



Emerald



Hunter Green



Royal Blue



Bluejay



Deep Violet



Navy



Bucksuede



Allspice



Cadet

Frame and upholstery colors applicable to the USA.  
 Product pricing is reflective of **standard** upholstery only.  
 Other color options available at an additional charge.  
 NOTE: Actual product colors may vary from what is shown here. † Iced Silver is stocked frame color.  
 Additional lead times may apply for other frame colors



# DESIGNED FOR SUPERIOR VALUE AND TRAINING VARIETY

## **XULT** SERIES

The Xult Series is the ideal choice for heavy-use facilities looking for a combination of performance and value. Smart design helps you make efficient use of your space and your budget, like our versatile functional trainers and plate-loaded equipment that provide conveniently contained personal training areas. If you're looking to accommodate a steady stream of users in a limited space, look no further than the Xult Series.



# XULT SERIES

## **DURABLE CONSTRUCTION**

Originally built to withstand the rigorous strength training of professional sports teams.

## **COLOR-CODED ADJUSTMENT POINTS**

Conveniently located and clearly marked for easy use.

## **VALUE**

Designed to handle a steady stream of users for years to come.





## XULT CONFIGURABLE RIGS

Our configurable rigs deliver outstanding durability and versatility for strength training in heavy-use environments. Tough 3" x 3", 11-gauge steel uprights provide excellent stability while offering multiple configurations, accessory attachment points and storage. Custom colors complement your brand, and the premium finish maintains a sleek aesthetic through hard use.







### ANGLED SMITH MACHINE

Olympic bar is counterbalanced to 11.3 kg / 25 lbs. • Olympic bar is mounted on linear bearings and shaft at a 7-degree angle • Open-ended frame design provides easy access • Flip in and out adjustable stops • 12 integrated weight-storage horns

	PRODUCT DIMENSIONS (L X W X H)						PRODUCT WEIGHT	
	CM			INCHES			KG	LBS
VY-M49	107	218	211	42	86	83	186	410



### PERFECT SQUAT

Large, angled, heavy-duty footplate adds stability • Adjustable starting position allows user to set pad height for squats or standing calf raises • Shoulder pads maintain parallel position to floor throughout full range of motion • 2 integrated weight-storage horns • Ideal for squats, calf work and reverse lunges

	PRODUCT DIMENSIONS (L X W X H)						PRODUCT WEIGHT	
	CM			INCHES			KG	LBS
VY-400	157	84	168	62	33	66	181	399



### LEG EXTENSION

Self-adjusting tibia pad enhances comfort • Back pad is adjustable from the seated position for proper alignment • 2 integrated weight-storage horns

	PRODUCT DIMENSIONS (L X W X H)						PRODUCT WEIGHT	
	CM			INCHES			KG	LBS
VY-401	102	157	117	40	62	46	91	200



### PRONE LEG CURL

Divergent angle of lower-leg pad eliminates lower-back stress • Neutral position handgrips enhance comfort and stability

	PRODUCT DIMENSIONS (L X W X H)						PRODUCT WEIGHT	
	CM			INCHES			KG	LBS
VY-402	173	91	72	68	36	30	91	200



### BICEPS CURL

Side arm pads encourage proper user positioning • 1 integrated weight-storage horn • Counterbalanced exercise arm offers optimal resistance

	PRODUCT DIMENSIONS (L X W X H)						PRODUCT WEIGHT	
	CM	INCHES		KG	LBS			
<b>VY-431</b>	97	107	112 38	42 44	68	150		



### TRICEPS EXTENSION

Adjustable knee pads help stabilize user during exercise • Side arm pads encourage proper positioning • 1 integrated weight-storage horn • Counterbalanced exercise arm offers optimal resistance

	PRODUCT DIMENSIONS (L X W X H)						PRODUCT WEIGHT	
	CM	INCHES		KG	LBS			
<b>VY-432</b>	97	107	140 38	42 55	68	150		



### PUSH SLED

Removable 3' poles • Dual carabiner anchor points • Heavy duty steel frame supports up to 350 lbs. per post

	PRODUCT DIMENSIONS (L X W X H)						PRODUCT WEIGHT	
	CM	INCHES		KG	LBS			
<b>MX-SLED</b>	100	67.5	97 39.4	26.6 38.2	24.5	54		



### A-FRAME DUMBBELL RACK W/KETTLEBELL STORAGE

Rack holds eight pairs of dumbbells • Built-in storage tray holds up to five kettlebells • Rubber feet provide stability and protect flooring

	PRODUCT DIMENSIONS (L X W X H)						PRODUCT WEIGHT	
	CM		INCHES				KG	LBS
<b>MX-AFRAME-DBKB-08</b>	81.5	65	156	32	25.5	61.3	26	57



### DUMBBELL FLAT RACK - 10 PAIR

Designed to hold dumbbells ranging up to 50 kg / 100 lbs. • Ideal for hex dumbbell sets • Rubber feet provide stability and protect flooring

	PRODUCT DIMENSIONS (L X W X H)						PRODUCT WEIGHT	
	CM		INCHES				KG	LBS
<b>MX-FLAT-DB-10</b>	74	132	107	29	52	42	68	150



### KETTLEBELL RACK

Open design makes it easy to access and rack kettlebells • Rubber feet provide stability and protect flooring

	PRODUCT DIMENSIONS (L X W X H)						PRODUCT WEIGHT	
	CM		INCHES				KG	LBS
<b>MX-KB-RACK</b>	64.5	137.5	80.5	25.3	54	31.7	39	86



### DUMBBELL SADDLE RACK - 10 PAIR

Curved cradles prevent dumbbell rolling • Rubber feet provide stability and protect flooring • Holds round or multisided dumbbells up to 45 kg / 100 lbs. • Rubber feet provide stability and protect flooring

	PRODUCT DIMENSIONS (L X W X H)						PRODUCT WEIGHT	
	CM		INCHES				KG	LBS
<b>MX-3TIER-SADDLE-10</b>	100	160	121	39.2	63	47.6	73.5	162



### 5-BALL MED BALL RACK

Holds up to five medicine balls • Rubber feet provide stability and protect flooring

MX-MEDBALL-RACK-05	36	PRODUCT DIMENSIONS (L X W X H)					PRODUCT WEIGHT		
		CM		INCHES			KG	LBS	
		28.5	133.5	14	11.2	52.5	6	13.2	



### 10-BALL MED BALL RACK

Holds up to ten medicine balls • Rubber feet provide stability and protect flooring

MX-MEDBALL-RACK-10	57.5	PRODUCT DIMENSIONS (L X W X H)					PRODUCT WEIGHT		
		CM		INCHES			KG	LBS	
		28.5	133.5	22.6	11.2	52.5	8	17.6	



### STABILITY BALL RACK

Accommodates up to three stability balls measuring 55 cm, 65 cm or 75 cm

MX-RACK-ST-BALL-03	PRODUCT DIMENSIONS (L X W X H)						PRODUCT WEIGHT		
	CM		INCHES				KG	LBS	
	81	81	179.5	31.9	31.9	70.6	14	31	



### STUDIO DUMBBELL RACK

Holds neoprene or studio dumbbells • Weight sizes are easily visible for use & storage

MX-DBSTUDIO-RACK	PRODUCT DIMENSIONS (L X W X H)						PRODUCT WEIGHT	
	CM		INCHES				KG	LBS
	60.4	133	157.5	23.8	52.4	62	130.5	288



### GROUP X PLATE AND BAR RACK

Holds up to 20 studio bars and plate sets • Includes total of 26 storage horns for collars and plates

MX-STUDIO-RACK	PRODUCT DIMENSIONS (L X W X H)						PRODUCT WEIGHT	
	CM		INCHES				KG	LBS
	183.4	68.6	106.8	72.2	27	63.3	90	198



### FIT MAT WALL RACK

Vertical storage for exercise mats • Holds up to 10 mats • Fits mats with 49.5 cm / 19.5" wide hanger spacing

MX-WALL-MAT-RACK	PRODUCT DIMENSIONS (L X W X H)						PRODUCT WEIGHT	
	CM		INCHES				KG	LBS
	16.5	64	6	6.5	25.2	2.4	2	4.4



### BARBELL RACK

2-sided horizontal set bar rack • Holds 10 straight or E-Z Curl bars • Integrated band or accessory storage hooks • Durable bar protection take-offs

	PRODUCT DIMENSIONS (L X W X H)						PRODUCT WEIGHT	
	CM		INCHES		KG	LBS		
VY-D68	98	88	138	38.5	34.5	54.5	42.2	93



### MULTI-ADJUSTABLE BENCH

Back adjusts into 5 positions: flat, 30, 45, 60 and 80 degrees • Seat adjusts into 2 positions • Handle and wheels provide easy movement • Optional VY-D85AK Kickstand allows bench to be stored vertically (as shown)

	PRODUCT DIMENSIONS (L X W X H)						PRODUCT WEIGHT	
	CM		INCHES		KG	LBS		
VY-D85A	145	57	47.7	57	22.75	18.75	40.5	89





### 3-STACK MULTI-GYM

3 weight stacks allow multiple users to exercise simultaneously • Stations include: multiple position chest / shoulder press, lat pulldown / low row, leg extension / prone leg curl

	PRODUCT DIMENSIONS (L X W X H)						PRODUCT WEIGHT		WEIGHT STACK	
	CM			INCHES			KG	LBS	KG	LBS
<b>G1-MG30</b>	282	323	218	111	127	86	592	1305	3 X 91	3 X 200



## SMITH MACHINE

Bar travel limited to 72 cm / 28.5" from the floor • 6 integrated weight-storage horns • Adjustable stops flip in and out for easy access

	PRODUCT DIMENSIONS (L X W X H)						PRODUCT WEIGHT		WEIGHT STACK	
	CM	INCHES				KG	LBS	KG	LBS	
<b>G1-FW161</b>	205	141	229	80.5	55.5	90	135	297	3 X 91	3 X 200

Weight plates are not included.

**XULT SERIES STANDARD FRAME COLORS**



Iced Silver†



Black Glossy



Matte Black†



Lace White



Polarized Titanium

**XULT SERIES FRAME COLOR OPTIONS**



Blue Streak



Hi-lite Yellow



Sunburst Orange



Blood Red

**XULT SERIES UPHOLSTERY COLOR OPTIONS**

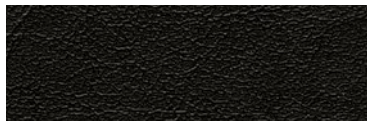

Black



Slate Blue

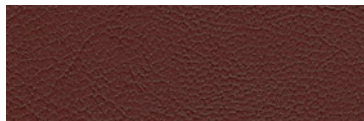

Clay Red

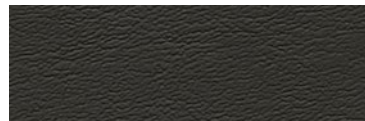

Graphite

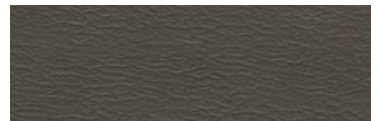

Alloy

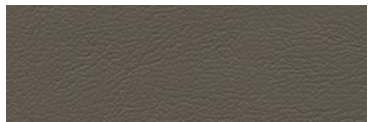

Hazelnut



American Beauty



Candy Apple



New Burgundy



Paprika



Nasturtium



Mandarin Orange



Sun Yellow



Marigold



Emerald



Hunter Green



Royal Blue



Bluejay



Deep Violet



Navy



Bucksuede



Allspice



Cadet

Frame and upholstery colors applicable to the USA.  
 Product pricing is reflective of **standard** upholstery only.  
 Other color options available at an additional charge.  
 NOTE: Actual product colors may vary from what is shown here. † Iced Silver is stocked frame color.  
 Additional lead times may apply for other frame colors



# BELIEVE IN ACCESSORIES THAT EMPOWER

## STRENGTH ACCESSORIES

The right accessories elevate exercise in all the right ways, making workouts more comfortable, more efficient, more effective and more in line with the unique goals of your members. Show lifters that they're in the right place with a complete selection of bars, benches, dumbbells and more. Count on lasting durability from these weight room essentials, plus thoughtful design features that make them unmistakably Matrix.





# DUMBBELLS & KETTLEBELLS



## ROUND RUBBER DUMBBELL

Solid steel core with high-quality rubber exterior • Sold as a pair

	PRODUCT WEIGHT	
	KG	LBS
<b>MX-RBR-RND</b>	2-45	5-100



## ROUND URETHANE DUMBBELL

Solid steel core with thick, high-grade urethane coating • Sold as a pair

	PRODUCT WEIGHT	
	KG	LBS
<b>MX-URE-RND</b>	2-45	5-100
<b>MX-URE-RND-P</b>	2-90	5-200



## HEX URETHANE DUMBBELL

Solid steel core with thigh, high-grade urethane coating • Sold as a pair

	PRODUCT WEIGHT	
	KG	LBS
<b>MX-URE-HEX-P</b>	1-23	2.5-50
	25-59	55-130



## MULTI-SIDED URETHANE DUMBBELL

Multi-sided design limits rolling allowing for stability on flat surfaces • Large, easy-to-read numbers • Sold as a pair

	PRODUCT WEIGHT	
	KG	LBS
<b>MX-URE-MTI-P</b>	2-68	5-150



## STUDIO URETHANE STUDIO DUMBBELL

Excellent use for group fitness and functional training • Ultra-premium, hard-wearing urethane coating • Hard chrome handle with stainless steel ring at joint • Sold as a pair

	PRODUCT WEIGHT	
	KG	LBS
<b>MX-URE-STU</b>	1-9	2-20

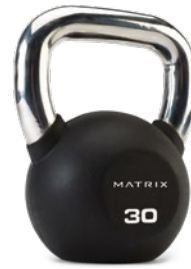

## RUBBER KETTLEBELL

Solid cast steel with durable virgin rubber finish • Stainless steel handle

	PRODUCT WEIGHT	
	KG	LBS
<b>MX-RBR-SS-KB</b>	2-41	5-90



## CAST KETTLEBELL

Matte powder finish is smooth while providing excellent grip • Wide, stable base

	PRODUCT WEIGHT	
	KG	LBS
<b>MX-CAST-KB</b>	2-41	5-90



## NEOPRENE DUMBBELL

Long-lasting neoprene coating • Sold individually

	PRODUCT WEIGHT	
	KG	LBS
<b>MX-NEO-STU</b>	0.5-7	1-15

# OLYMPIC BARS



## OPTIMA OLYMPIC BAR

Full and bench knurled grips with needle bearings for smooth and even rotation during lifts • Fits standard Olympic-sized plates

	BAR LENGTH		BAR DIAMETER		MAX WEIGHT		PRODUCT WEIGHT	
	M	IN	MM	IN	KG	LBS	KG	LBS
<b>MX-20KG-OLY-BZ-FK</b>	2.2	86.5	28.5	1.1	907	2000	20	44



## OPTIMA BENCH KNURL BAR

Knurled grips with needle bearings for smooth and even rotation during lifts • Available in silver or black

	BAR LENGTH		BAR DIAMETER		MAX WEIGHT		PRODUCT WEIGHT	
	M	IN	MM	IN	KG	LBS	KG	LBS
<b>MX-20KG-OLY-BZ-BK</b>	2.2	86.5	28.5	1.1	907	2000	20	44
<b>MX-20KG-32MM-134</b>	2.2	86	32	1.3	680	1500	20	44



## SELECT OLYMPIC BAR

Knurled grips with needle bearings for smooth and even rotation during lifts • Fits standard Olympic-sized plates

	BAR LENGTH		BAR DIAMETER		MAX WEIGHT		PRODUCT WEIGHT	
	M	IN	MM	IN	KG	LBS	KG	LBS
<b>MX-15KG-OLY-BZ-FK</b>	2	78.5	25	1	68	150	15	33
<b>MX-5-30MMBAR</b>	1.5	60	30	1.2	317.5	700	12	26



## SELECT JUNIOR OLYMPIC BAR

Knurled grips with needle bearings for smooth and even rotation during lifts • Fits standard Olympic-sized plates

	BAR LENGTH		BAR DIAMETER		MAX WEIGHT		PRODUCT WEIGHT	
	M	IN	MM	IN	KG	LBS	KG	LBS
<b>MX-10KG-JNR-BZ-FK</b>	1.6	64	25	1	272	600	10	22



## OLYMPIC SPRING COLLAR

Holds Olympic Plates in place • Sold as a pair

	DIMENSIONS	
	MM	INCHES
<b>MX-SPRING COLLAR</b>	50	2

# BARs



## OPTIMA POWER BAR

Knurled grips to loadable sleeves with powerlifting and Olympic marks • No whip, stiff flex for powerlifting • Fits standard Olympic-sized plates

	BAR LENGTH		BAR DIAMETER		MAX WEIGHT		PRODUCT WEIGHT	
	M	IN	MM	IN	KG	LBS	KG	LBS
<b>MX-20KG-PWR-BZ-FK</b>	2.2	86.5	28	1.1	544	1200	20	44



## OPTIMA PRECISION BAR

Knurled grip extends to loadable sleeves with olympic marks • Meets IWF standards • Ten precision needle bearings

	BAR LENGTH		BAR DIAMETER		MAX WEIGHT		PRODUCT WEIGHT	
	M	IN	MM	IN	KG	LBS	KG	LBS
<b>MX-20KG-IWF-HC-FK</b>	2.2	86.5	28	1.1	907	2000	20	44



## CLASSIC TECHNIQUE BAR

Light knurling with Olympic and powerlifting marks • Engineered to help teach olympic-style and power lifts

	BAR LENGTH		BAR DIAMETER		MAX WEIGHT		PRODUCT WEIGHT	
	M	IN	MM	IN	KG	LBS	KG	LBS
<b>MX-15LB-TRN-AL-FK</b>	1.6	64	28	1.1	68	150	7	15



## EZ CURL BAR

Ideally shaped for curls • Available in silver

	BAR LENGTH		BAR DIAMETER		MAX WEIGHT		PRODUCT WEIGHT	
	M	IN	MM	IN	KG	LBS	KG	LBS
<b>MX-4-30MMEZ</b>	1.2	48	30	1.2	226.8	500	10	24

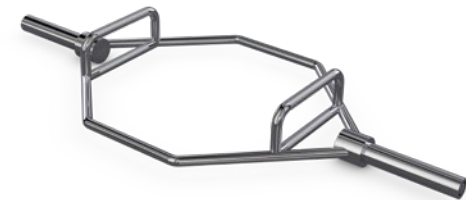

## OLYMPIC HEX TRAP BAR

Ideal for squats, deadlifts, shrugs and power pulls • Knurled grips with bearings for smooth and even rotation • Holds Olympic plates

	BAR LENGTH		BAR DIAMETER		MAX WEIGHT		PRODUCT WEIGHT	
	M	IN	MM	IN	KG	LBS	KG	LBS
<b>MX-27.5KG-TRAP-BAR</b>	1.4	56	30	1.1	227	500	27	60

# BARs



## SAFETY SQUAT BAR

Hard-chrome coated bar with padded harness and additional handles • Knurled grips with needle bearings for smooth and even rotation

	BAR LENGTH		BAR DIAMETER		MAX WEIGHT		PRODUCT WEIGHT	
	M	IN	MM	IN	KG	LBS	KG	LBS
<b>MX-65LB-SQUAT</b>	2.3	92	38	1.5	680	1500	29.5	65



## OLYMPIC TRICEP BAR

Ergonomic design relieves discomfort in hands, wrists and elbows • Revolving sleeves feature high-quality brass bushings

	BAR LENGTH		BAR DIAMETER		PRODUCT WEIGHT	
	M	IN	MM	IN	KG	LBS
<b>MX-10KG-TRICEP</b>	0.9	34	30	1.2	13	29

# BARBELLS



## ROUND RUBBER BARBELL

High-quality virgin rubber • Available in Straight or EZ Curl

	PRODUCT WEIGHT	
	KG	LBS
MX-RBR-BBEZ & MX-RBR-BBST	9-50	20-110



## ROUND URETHANE BARBELL

High-grade odorless urethane covering • Available in Straight or EZ Curl

	PRODUCT WEIGHT	
	KG	LBS
MX-URE-BBST & MX-URE-BBEZ	10-45	22.05-99.21
MX-URE-BBST-P & MX-URE-BBEZ-P	9-49.8	20-100



## MULTI-SIDED URETHANE BARBELL

Wear-resistant, matte-textured surface • Available in Straight or EZ Curl

	PRODUCT WEIGHT	
	KG	LBS
MX-URE-BBEZM-P & MX-URE-BBSTM-P	9-50	20-110

# BARBELLS



## GROUP X BARBELL

Fits most studio / Group X plates • Weights not included • Sold individually

	BAR DIAMETER	
	MM	IN
<b>MX-BARGRPX</b>	25	1



## GROUP X COLLAR

Group X collar designed specifically for the Group X Barbell

	BAR DIAMETER	
	MM	IN
<b>MX-COLLARGPX</b>	25	1

# PLATES



## URETHANE GRIP PLATE

Easy-grip handles on three sides • Solid stainless-steel insert • Durable urethane coating

	PRODUCT WEIGHT	
	KG	LBS
<b>MX-URE-PLATE</b>	1-20	2.5-45



## PREMIUM URETHANE GRIP PLATE

Premium rubberized surface coating • Easy-grip handles on three sides • Sold individually

	PRODUCT WEIGHT	
	KG	LBS
<b>MX-URE-PLATE-P</b>	1-20	2.5-45



## BUMPER PLATE

Olympic-standard strength training plates • Designed with a low-bounce feature to withstand repeated drops • Available in urethane and rubber, and each are available in color and black

	PRODUCT WEIGHT	
	KG	LBS
<b>MX-RUBR-BP &amp; MX-URE-BP</b>	5-20	10-45

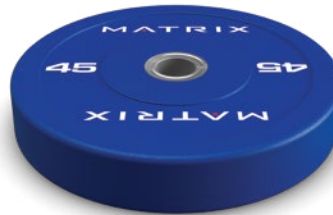

## TRAINING BUMPER PLATE

Matte-textured surface • Dead bounce for added safety • Available in black and color

	PRODUCT WEIGHT	
	KG	LBS
<b>MX-RUBR-BP-TRAIN</b>	5-20	10-45



## GROUP X URE PLATE

Thick high-grade urethane • Two comfortable handles • Large easy-to-read numbers • Anti-roll design • Sold individually

	PRODUCT WEIGHT	
	KG	LBS
<b>MX-02.5UREGRPX</b>	1	2.5
<b>MX-05UREGRPX</b>	2	5
<b>MX-10UREGRPX</b>	5	10

# CABLE ATTACHMENTS



## REVOLVING STRAIGHT BAR

Solid steel core with high-quality rubber exterior • Sold as a pair

**MX-20-REVOLVE-STR**



## TRICEPS PRESS DOWN ROPE

Solid steel core with thick, high-grade urethane coating • Sold as a pair

**MX-TRICEP-ROPE**



## MULTI-PURPOSE V-BAR

Solid steel core with thick, high-grade urethane coating • Sold as a pair

**MX-MULTI-V**



## PRO STYLE REVOLVING LAT BAR

Designed specifically for group fitness and functional training • Wide base suitable for functional exercises • Large, easy-to-read numbers • Sold as a pair

**MX-34-REVOLVE-LAT**



### SEATED ROW / CHINNING BAR

Excellent use for group fitness and functional training • Ultra-premium, hard-wearing urethane coating • Hard chrome handle with stainless steel ring at joint • Sold as a pair

**MX-SEATROW**



### REVOLVING CURL BAR

Solid cast steel with durable virgin rubber finish • Chrome handle

**MX-28-REVOLVE-CRL**



### TRICEPS PRESS DOWN BAR

Precision steel bell with premium urethane surface coating • Electroplated 34 mm / 1.34" solid steel handles

**MX-TRICEP-BAR**



### REVOLVING LAT BAR

Long-lasting neoprene coating • Sold individually

**MX-48-REVOLVE-LAT**



### DELUXE STIRRUP HANDLE

Wear-resistant, matte-textured surface • Available in Straight or EZ Curl

**MX-DELUXE-STIRRUP**

# A TRULY GLOBAL COMPANY

## **AUSTRALIA / NEW ZEALAND**

Johnson Health Tech Australia Pty. Ltd.

## **BRAZIL / CHILE**

Johnson Health Tech Brasil

## **BULGARIA**

Johnson Health Tech Bulgaria

## **CANADA**

Johnson Health Tech Canada

## **CHINA**

Johnson Health Tech (Shanghai) Co., Ltd.

## **CZECH REPUBLIC / SLOVAKIA**

Johnson Health Tech CZ & SK a.s.

## **DENMARK**

Johnson Health Tech Denmark ApS

## **FRANCE**

Johnson Health Tech France

## **GERMANY / AUSTRIA**

Johnson Health Tech GmbH

## **GREECE / CYPRUS / ALBANIA**

Johnson Health Tech Hellas SA

## **HONG KONG**

Johnson Health Tech Hong Kong

## **HUNGARY**

Johnson Health Tech Hungary Ltd.

## **INDIA / BANGLADESH / SRI LANKA**

Johnson Health Tech India, Pvt. Ltd.

## **ITALY / MALTA**

Johnson Health Tech Italia Spa

## **INDONESIA**

Johnson Health Tech Indonesia

## **JAPAN**

Johnson Health Tech Japan

## **KOREA**

Johnson Health Tech Co., Ltd. Korea

## **MALAYSIA**

Johnson Fitness (Malaysia) SDN. BHD.

## **MEXICO**

Johnson Health Tech Mexico

## **NETHERLANDS / BELGIUM / LUXEMBOURG**

Johnson Health Tech Benelux

## **PHILIPPINES**

Johnson Health Tech Philippines Inc.

## **POLAND**

Johnson Health Tech Sp. Z. O. O.

## **ROMANIA / MOLDOVA**

Johnson Health Tech Romania

## **RUSSIA**

Johnson Health Tech Russia

## **SOUTH AFRICA**

Johnson Health Tech South Africa (PTY) Ltd.

## **SPAIN / PORTUGAL**

Johnson Health Tech Ibérica SL

## **SWITZERLAND**

Johnson Health Tech (Schweiz) GmbH

## **TAIWAN**

Johnson Health Tech Taiwan

## **THAILAND / CAMBODIA / LAOS / MYANMAR**

Johnson Health Tech (Thailand) Co., Ltd.

## **TURKEY**

Johnson Health Tech Turkey

## **UNITED ARAB EMIRATES / JORDAN / KUWAIT / OMAN / QATAR / SAUDI ARABIA / EGYPT**

Johnson Health Tech Middle East

## **UNITED KINGDOM**

Johnson Health Tech UK Ltd.

## **UNITED STATES**

Johnson Health Tech North America

## **VIETNAM**

Johnson Health Tech (Vietnam) Co. Ltd.

Visit [matrixfitness.com](http://matrixfitness.com) for full contact information.

# MATRIX

In 2001, Johnson Health Tech established Matrix Fitness to bring premium fitness equipment to the marketplace. Since then, we've become the fastest-growing commercial fitness equipment brand in the world. Matrix has leveraged continuous innovation and cross-cultural collaboration to emerge as an industry vanguard, constantly challenging standards and raising expectations for fitness equipment design and exercise technology.

Our product portfolio has expanded to over 600 products including strength equipment, cardio platforms, group exercise modalities, athletic performance training tools, fitness technology, integrated HIIT workouts, turnkey programming and much more. With nearly 40 subsidiaries around the world, Matrix is uniquely equipped to meet fitness and wellness needs in every corner of the globe.

Today, Matrix Fitness is dedicated to serving fitness facilities of all kinds, setting them apart in ways that attract and retain more members. Our mission is to delight and excite our customers through complete solutions and committed partnership provided by a world-class organization.







**MATRIX**  
Strong • Smart • Beautiful

**Matrix Fitness**

1600 Landmark Drive  
Cottage Grove, WI 53527 USA

   matrixfitnessusa  
matrixfitness.com | 866.693.4863

©2026 Matrix Fitness. All Rights Reserved.

AUTHORIZED MATRIX FITNESS DISTRIBUTOR

